

madridjoya

International Exhibition of Urban and Trendy
Jewellery and Watches

Exhibitor's Guide and Specific
Rules for Participation

Coinciding with:

bisutex

24-27
Sep
2026

ifema.es



INDEX

1. HOW TO PARTICIPATE. REGULATIONS

- 1.1 Dates. Timetable and venue Sectors convened
- 1.2 What do I have to do to participate?
- 1.3 Contracting and allocation of spaces
- 1.4 Your Exhibitor Plan. liveconnect: The digital platform you have access to with your plan.
- 1.5 Participation modalities
- 1.6 Your space at the fair. Types of stands. Regulations and assembly
- 1.7 Participation fees
- 1.8 Deadlines and forms of payment
- 1.9 Specific participation rules
- 1.10 Exhibitor's calendar

2. MANAGE YOUR PARTICIPATION

- 2.1 Expo Zone. Manage your participation and your space
Contracting additional services. E-commerce
- 2.2 Exhibitor passes and invitations. Visas. Vouchers and discounts
- 2.3 liveconnect: the digital platform to which you have access with your Plan.
- 2.4 Other relevant information.
- 2.5 Floor plan
- 2.6 Frequently Asked Questions

3. PROMOTE AND MONETIZE YOUR PARTICIPATION

- 3.1 How to monetize my participation
- 3.2 Exhibitor Catalog
- 3.3 Visitor's Guide Map
- 3.4 Networking
- 3.5 Invitations for your clients and contacts
- 3.6 Buyers Program
- 3.7 Publish your news and novelties. RRSS and WEB
- 3.8 Outdoor and digital advertising
- 3.9 Sponsorships
- 3.10 Special promotional actions
- 3.11 Conferences, Demonstrations, and Seminars at the Fair
- 3.12 Room rental

4. SUSTAINABILITY MANAGEMENT AT IFEMA MADRID

5. CONTACT WITH US

1.1 Dates, Schedule, and Venue. Participating Sectors

Madridjoya will take place at the IFEMA MADRID fairgrounds from **September 24 to 27, 2026**, the schedule will be from 10:00 AM to 7:00 PM. On 27, the schedule will be from 10:00 AM to 4:00 PM.

Exhibitors will be able to access the venue from 9:00 AM and must leave by 4:30 PM on Sunday.

The virtual event via the Madridjoya liveconnect platform will be open from June 30 to October 30, 2026.

The fair is exclusively for professionals.

Participating Sectors:

- Gold and silver jewelry
- Watchmaking
- Precious stones, semi-precious stones, and gems
- Goldsmithing
- Related industries: packaging and display cases, trade press, associations, and machinery.

1.2 What do I have to do to participate?

The space rental is formalized through the **ONLINE PARTICIPATION REQUEST** form, available on the fair's website: <https://www.ifema.es/madri-joya>.

To apply for participation in the fair, it is required that the exhibitor's activity falls within the sectors covered by the event. The exhibiting company is the one that will participate in the fair and in whose name the participation request is completed.

This form allows IFEMA MADRID to provide detailed information and submit a participation proposal, which constitutes a contract offer. Its acceptance requires a binding commitment from the exhibitor.

If the EXHIBITING COMPANY designates another entity to make any payments related to its participation, it must complete the corresponding section of the Participation Request. In any case, if the designated billing company fails to make the payments within the indicated deadlines, the EXHIBITING COMPANY will be responsible for them upon simple request from IFEMA MADRID.

Submitting the **Participation Request** implies full acceptance of the **General Rules of Participation in Exhibitions organized by IFEMA MADRID**

By clicking the submit button **on the request**, the exhibitor confirms their firm interest in participating and in receiving a proposal from IFEMA MADRID.

From the same application platform, if the process is not completed, it is possible to request information and quotes. This does not constitute a formal request for an offer **nor does it require the payment of the reservation fee.**

1.3 Contracting and allocation of spaces

The decision to accept the exhibitor will be at the discretion of IFEMA Madrid, taking into account the purpose of the fair and the availability of spaces.

IFEMA Madrid may make one or several location proposals based on the type of participation and the characteristics of the requested stand. This proposal constitutes a contract offer, and its written acceptance (by email or signature) formalizes the participation contract, which will be binding and non-revocable by the applicant.

The space will be assigned after the exhibitor's written acceptance. Once confirmed, the exhibitor will receive the exhibition contract with the account statement and the location plan and measurements of their stand. From that moment on, they will be able to access the Zona Expo client portal to manage their participation.

It is essential to make the payments indicated in the contract within the established deadlines.

1. HOW TO PARTICIPATE. REGULATIONS

Madridjoya

1.4. Exhibitor Plan Conecta liveconnect: the digital platform you have access to with your Plan.

Participation as an exhibitor at the fair requires the CONECTA EXHIBITOR PLAN at €450 + VAT (1).

The Connect Plan includes:

- **Dissemination of participation:** Insertion in the list of exhibitors accessible in open access on the fair's website and shared as a link in sectorial communications.
- **Digital presence:** Participation as an exhibitor in Madridjoya liveconnect, the online platform that extends the fair beyond its celebration, providing exclusive content on the exhibition offer and sector news. Available to exhibitors and registered visitors.
- **Registration of 10 products** or services associated with the company file in liveconnect.
- **Presence in floor plans and listings:** Inclusion during the fair in the pavilion floor plans and exhibitor lists.
- **Access to IFEMA MADRID's "EXPO ZONE"** to manage your participation.
- Exhibitor passes according to the contract (see point 2.3).
- **Online invitations** according to the contract (see point 2.3).
- **Discount vouchers** for transportation to facilitate your transfer.
- **Premium wifi connection for 3 users** during the fair, available only for devices with 5 GHz band. The password will be sent by email 48 hours before and will be active until the last day of dismantling.
- **Access for 3 users to the liveconnect platform.**

What will you find in liveconnect?

- liveconnect is the digital ecosystem **that fosters connections with**
- **Other professionals**, facilitating meeting preparation, offering exclusive content and activities, and generating business opportunities.
- **Business and networking** Identify leads to generate business and schedule high-value meetings.
- **Post-fair ecosystem** Activity and visibility after the fair: access and share content, participate in challenges, and much more.

What can you do from your Exhibitor area in liveconnect?

- Update your company data visible in the web catalog and Madridjoya liveconnect.
- Add your products and services, which will be visible in Madridjoya liveconnect.
- Register team members so they can access the Madridjoya liveconnect digital event.
- Manage your schedule and coordinate meetings at your stand during the fair.

What can I do at the Madridjoya liveconnect digital event?

- Complete your professional profile and set up your meeting schedule.
- Search and connect with relevant contacts in the professional network.
 - Communicate via chat or video conference. Organize online and in-person meetings.
 - View the offerings of other exhibitors. Browse and schedule activities and conferences. Scan visitor passes at the fair.
 - Download your contact list.



1.5. Participation Modalities and Exhibition Areas

- **Exhibitor:** refers to the natural or legal person who has a space at the event. The exhibiting company is the one in whose name the participation request as an exhibitor is completed.

The exhibitor has the option to rent a modular stand, a "**turnkey stand**," or simply rent the space to build their own "**custom-designed stand**."

Companies with an area of less than 25sq.m are required to rent one of the modular stand packages.

- In the **Madridj oya Area (Hall 3)**
 - A. Closed Modular Stand: Minimum area of 12sq.m
 - B. Premium Open Modular Stand: Minimum area of 12sq.m
 - C. Mini Modular Stand: 9sq.m
 - D. Custom-Designed Stand: Minimum area of 25sq.m

Before August 31st, 2026, you must confirm through your Expo Zone the name that will appear on the stand's signage.

1.6. Their space at the fair. Types of stands. Regulations and setup

TYPES OF STAND

Exhibition areas and types of setup for each area.

- **Closed Modular Stand:** Intended for companies and firms displaying product samples. Minimum area 12 sq.m .
- **Open Premium Modular Stand:** Intended for companies and firms displaying product samples. Minimum area 12 sq.m .
- **Mini Modular Stand:** Intended for companies and firms displaying product samples. Area 9 sq.m .
- **FREE DESIGN Stand (floor only):** Intended for companies and firms that choose to build a stand tailored to their image objectives. Area equal to or greater than 25 sq.m .
- **Exceptionally,** the Commercial Management may authorize the construction of free-design stands for companies with less than 25 sq.m that provide a special and distinctive design compared to the modular stands, upon submission of the corresponding project through the Expo Zone.

Participation with a stand at the fair requires the contracting of the following services from IFEMA MADRID:

- Civil Liability Insurance (covers up to €60,000)(*)
- Multi-Fair Insurance (covers up to €50,000)(*)
- Minimum electricity consumption (0.16 kW/sq.m)(*)

- Assembly rights **only for Free Design Stand** (*)

- **Type A:** Spaces without decoration or covered with carpet or flooring.
- **Type B:** Basic modular stands made of aluminum or similar materials.
- **Type C:** Modular design stands in aluminum, carpentry stands, and other materials.

- **Conecta Exhibitor Plan.**

(*) Services already included in the Mini Modular Stand.

Participation with a stand at the fair requires the contracting of the following services from IFEMA MADRID:

- Civil Liability Insurance (covers up to €60,000)(*)
- Multi-Fair Insurance (covers up to €50,000)(*)M
- Minimum electricity consumption (0.16 kW/sq.m)(*)
- Assembly rights only for Free Design Stand (*)
- **Type A:** Spaces without decoration or covered with carpet or flooring.
- **Type B:** Basic modular stands made of aluminum or similar materials.
- **Type C:** Modular design stands in aluminum, carpentry stands, and other materials.

- **Conecta Exhibitor Plan.(*)**

Services already included in the Mini Modular Stand.

TYPE OF STAND

CLOSED MODULAR STAND

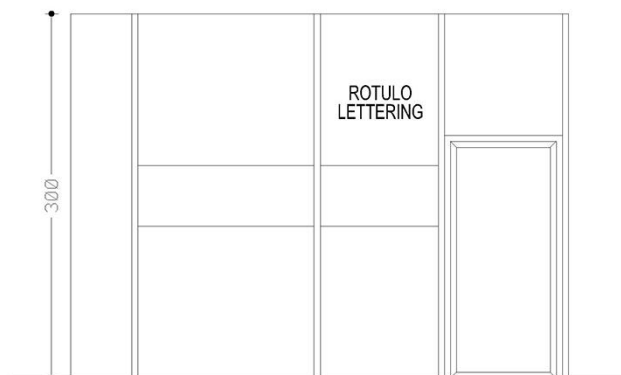
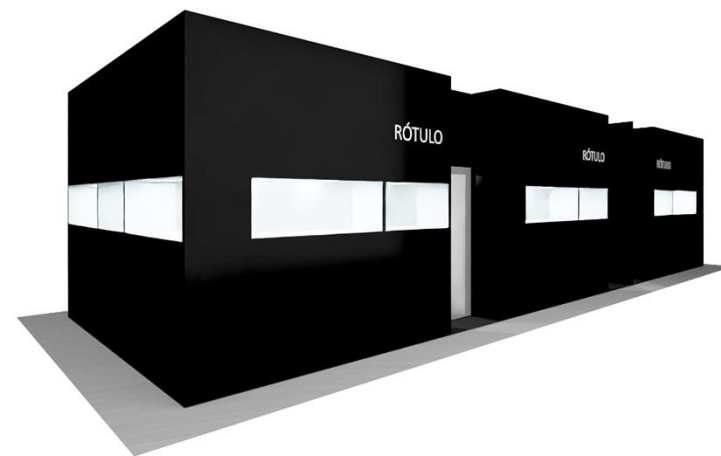
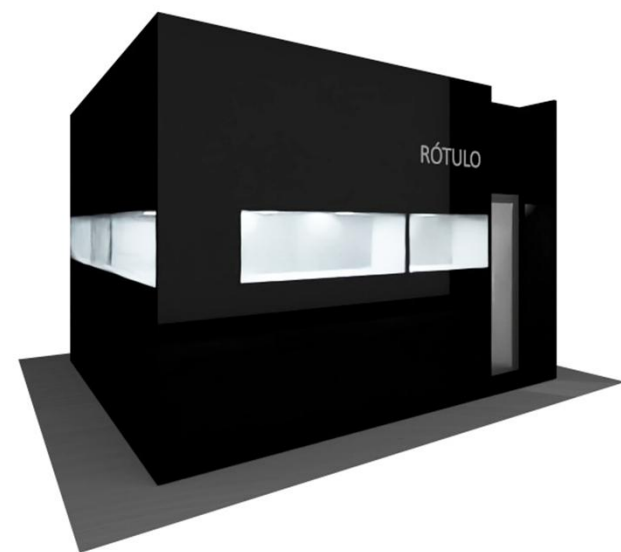

ORIENTATIVE DRAWING

STAND

- Closed stand to one or more aisles depending on the location.
- Structure at 2.90m height made with matte black melamine panels and custom-built display cases at height.

FAIR TYPE CARPET



Black

PLAY CASES

Included per stand according to sq.m :

- Up to 16sq.m , a maximum of 5 linear meters of display case. From 16.50sq.m to 24sq.m , a maximum of 6 linear meters of display case.
- From 24.50sq.m to 32sq.m , a maximum of 7 linear meters of display case.
- From 32.50sq.m to 48sq.m , a maximum of 8 linear meters of display case.
- Starting from 48.50sq.m and beyond, a maximum of 9 linear meters of display case.

STORAGE AREA

Included per stand according to sq.m :

- Up to 16sq.m : 1x1
- From 16.5sq.m to 32sq.m : 2x1
- Starting from 32.5sq.m : 3x1

SIGNAGE

Standard lettering signage placed next to the door. Through the Expo Zone, they should indicate **by September 7th** for all modular stands the name that should appear on the stand's sign.

LIGHTING

Electrical panel with a magnetothermal differential switch and an integrated power socket.

- One spotlight for every 4sq.m of the stand.
- Electrical panel with residual-current device (RCD), circuit breaker, and a built-in 500 W socket outlet, prepared for a power capacity of 130W/M2

VIEW RATES

ORIENTATIVE DRAWING: Drilling or nailing is not allowed. It is allowed to stick with tape whose removal does not damage the panels and can be removed later..

OBSERVATIONS: All services or modifications desired beyond these characteristics will be at the exhibitor's expense. • The removal or replacement of any modular stand component by the exhibitor does not imply a reduction in cost. • The distribution of all elements that make up the stand, requested extras, and structural elements necessary for the stand's support will be adapted to the exhibitor's needs, as long as it is technically feasible and the plan with the relevant instructions is received fifteen days before the first day of assembly. Once the stand assembly is completed, any changes in the location of elements that have not been communicated by the established date will be charged. • All material used, both structural and electrical, is under a rental regime, and any deterioration will be charged according to the current rate. • Additionally, any exhibitor may hire elements listed in IFEMA's Services Catalog.

TYPE OF STAND

OPEN PREMIUM MODULAR STAND



ORIENTATIVE DRAWING

STAND

- Open stand to one or more aisles, depending on the location.
- White fabric walls on columns made of particleboard painted in beige

FAIR TYPE CARPET



CANVAS WALLS

The canvas walls that form the stand have a thickness of 30 cm, reducing the interior space of the stand. To install the wall shelves offered in the [Expo Zone](#), it will be necessary to hire painted particleboard panels instead of the canvas or fabric. Likewise, if a storage area is needed, it can be hired additionally with the required dimensions.

ELECTRICAL ENERGY AND LIGHTING

- Lighting based on LED strips placed between the fabric walls.
- One 50W lamp per linear meter of free space between the outer columns.
- Electrical panel with differential, magnetothermal, and an integrated 500W power socket, prepared for a power of 130W/sq.m.

SIGNAGE

In standard lettering on each facade facing the aisle. Through the [Expo Zone](#), they should indicate **by September 7th** for all modular stands the name that should appear on the stand's sign.

INCLUDED SERVICES

Stand cleaning once a day (Type A).

ASSEMBLY PLAN.

You can view your assembly plan and track the status of the plan, as well as make observations about it. If any changes are needed, please indicate them through the [Expo Zone](#) **before August 31st** for all modular stands.

[VIEW RATES](#)

ORIENTATIVE DRAWING. Drilling, nailing, or sticking is not allowed. It will be adapted to the dimensions of the assigned space.

OBSERVATIONS: All services or modifications desired beyond these characteristics will be at the exhibitor's expense. • The removal or replacement of any modular stand component by the exhibitor does not imply a reduction in cost. • The distribution of all elements that make up the stand, requested extras, and structural elements necessary for the stand's support will be adapted to the exhibitor's needs, as long as it is technically feasible and the plan with the relevant instructions is received fifteen days before the first day of assembly. Once the stand assembly is completed, any changes in the location of elements that have not been communicated by the established date will be charged. • All material used, both structural and electrical, is under a rental regime, and any deterioration will be charged according to the current rate. • Additionally, any exhibitor may hire elements listed in IFEMA's Services Catalog.

1. HOW TO PARTICIPATE. REGULATIONS

TYPE OF STAND

MINI STAND



ORIENTATIVE DRAWING

STAND

- Open stand to aisles of 9 sq.m
- Structure made of particleboard panels painted in matte white plastic.

FAIR TYPE CARPET



ELECTRICAL ENERGY AND LIGHTING

- Lighting using 2 LED spotlights per stand.
- Electrical panel with a differential, magnetothermal switch, and an integrated 500W power socket, prepared for a power of 130W/sq.m .

FURNITURE (regardless of the contracted sq.m):

- 1 White Dom Table (6RL02001)
- 2 Madrid Chairs (6RL01001)
- 3 Low Cabinets
- 4 Mobile Shelf



SIGNAGE

Signage in standard lettering on each face facing the aisle. Through the [Zon Expo](#) , they should indicate **by September 7th** for all modular stands the name that should appear on the stand's sign.

ASSEMBLY PLAN.

You can view your assembly plan and track its status, as well as make observations about it. If any changes are needed, please indicate them through the Expo Zone **before August 31th** for all modular stands.

INCLUDED SERVICES

- Electricity consumption. Multi-fair insurance and civil liability insurance.
- Daily cleaning of Type A stand.
- Communication and marketing pack + liveconnect.

[VIEW RATES](#)

ORIENTATIVE DRAWING. Drilling is not allowed. However, nailing or sticking with adhesive tape is permitted. It will be adapted to the dimensions of the assigned space.

OBSERVATIONS: All services or modifications desired beyond these characteristics will be at the exhibitor's expense. • The removal or replacement of any modular stand component by the exhibitor does not imply a reduction in cost. • The distribution of all elements that make up the stand, requested extras, and structural elements necessary for the stand's support will be adapted to the exhibitor's needs, as long as it is technically feasible and the plan with the relevant instructions is received fifteen days before the first day of assembly. Once the stand assembly is completed, any changes in the location of elements that have not been communicated by the established date will be charged. • All material used, both structural and electrical, is under a rental regime, and any deterioration will be charged according to the current rate. • Additionally, any exhibitor may hire elements listed in IFEMA's Services Catalog.

REGULATIONS AND ASSEMBLY OF YOUR SPACE

ASSEMBLY AND DISASSEMBLY

All companies are required to assemble their stand, including the partition walls with the pavilion wall and neighboring stands, according to their location.

The **assembly of free-design stands** can be carried out from **September 18 to 22, 2026**, during the following hours:

- ✓ September 18, 21 and 22, and 9 from 8:30 AM to 9:30 PM.
- ✓ September 19 and 20 from 8:30 AM to 7:30 PM.

The **delivery of modular stands** contracted with IFEMA MADRID will be made on **23 September starting at 8:30 AM**.

Exceptionally, and upon express request to Madridjoya@ifema.es, access with decoration materials or machinery will be authorised if required on September 22.

Exhibitors who have not paid in full for the space contracted and the costs of the services requested will not be authorised to occupy the space or take delivery of the stand.

Goods may be brought in on **23 September** from **8:30 a.m. to 9:30 p.m.** **From 7:00 p.m. on 23 September**, entry will only be possible through the pedestrian doors, as the goods doors will be closed to allow for the installation of recyclable carpet.

Goods and materials may be removed on **27 September** from **4:30 p.m. to 22:00 p.m.**

Stands may be dismantled on **28 September 2026** from **06:00 a.m. to 00:00 a.m.**

General Assembly Regulations

For **safety** reasons, and as a general and permanent preventive measure due to the concurrent activities, it **is mandatory to wear a protective helmet, high-visibility vest, and safety footwear during the assembly and disassembly phases of fairs and events in all exhibition areas.**

During assembly, passes are not required, so there are no assembly passes.

Assembly work cannot begin without the prior completion and submission of the "Occupational Risk Prevention and Coordination of Business Activities" Protocol to IFEMA, available on the IFEMA MADRID website ifema.es - Exhibitors - Participation Rules - Forms (Article 15 of the general participation rules for events organized by IFEMA MADRID).

Regulations on Vehicle Circulation and Parking During the Event

It is strictly prohibited to keep vehicles parked in the loading and unloading areas within the exhibition grounds, and they may only be parked in designated areas, paying the corresponding fee if applicable. Once the event is inaugurated, vehicles are not allowed to circulate inside the halls and the avenue, except with express authorization from IFEMA MADRID (Article 14 of the general provisions of IFEMA MADRID's participation rules).

Waste and Assembly/Exhibition Material Management: All companies participating in the assembly and disassembly of stands for the fair/event must manage, as direct responsible parties, the waste they generate for removal within the established deadlines. IFEMA MADRID will provide the option to rent containers to facilitate waste sorting and removal, and will supervise this process (see rates in the Client Portal, Expo Zone, under Service Contracts, section on cleaning and waste containers). The exhibitor will forfeit any right to claim for losses or damage to materials that remain in the exhibition areas of the pavilion after the deadline and will be responsible for the costs of their removal, which will be invoiced by IFEMA MADRID according to the established rates (see Article 35 of the general participation rules for exhibitors in events organized by IFEMA MADRID).

AUTORIZACIONES ESPECIALES

On the ifema.es website, you will find a list of other services, regulations, and forms that may be of interest to you:

Communication for catering services at stands. Catering at stands <https://www.ifema.es/en/doc/catering-stands-communication---recinto-ferial/catering-stands-recinto-ing.pdf>

- Occupational risk prevention and coordination of business activities.
- Request for authorization of private security at stands.
- Request for authorization for Wi-Fi installation.
- Request for authorization for antenna cabling.
- Request for authorization to hang structures/rigging.

<https://www.ifema.es/soporte/expositores-ifema-recinto>

1. HOW TO PARTICIPATE. REGULATIONS

REGULATIONS AND ASSEMBLY OF YOUR SPACE

Installation of Recyclable Carpet in Common Areas: In line with IFEMA MADRID's commitment to the 2030 SDGs (United Nations Sustainable Development Goals), as outlined in [the Sustainable Participation Guide for Fairs and Events](#), and with the goal of optimizing the installation and removal process of recyclable fair carpets for subsequent reuse and the consequent elimination of protective plastic at the source, the entry and exit times for goods must align with these processes and will be reflected in the corresponding section. Thank you for your collaboration with our environmental commitment.

Turnkey Stands. Regulations and Customization.

All modular stands that include interior decoration with panels, profiles, totems, platforms, trusses, etc., **MUST UPDATE their project** in their Expo Zone **before 31 August 2026**.

The removal or replacement of any element of the 'TURNKEY' modular stand by the exhibitor will not result in a reduction in cost. All materials used, both structural and electrical, are rented and any damage will be invoiced according to the current rates.

The **deadline** for modifying the turnkey and mini **stand signage is 7 September 2026**.

The distribution of all the elements that make up the stand, the requested extras, as well as the structural elements necessary for the stand's support, will be adapted to the exhibitor's needs, as long as it is technically feasible and the plan with the relevant instructions IS UPLOADED TO EXPO ZONE 15 days before the assembly begins: September 3, 2026.

CUSTOMIZE YOUR STAND WITH US: GRAPHIC DECORATION FOR STANDS

Customize your modular stand with your brand image to make the maximum impact on visitors. We offer a wide range of graphic materials (vinyl, foam, Forex, banners, etc.) that are versatile and adaptable to all stand elements (walls, furniture, fascia, flags, displays...). Request more information and a quote. Our specialized team will oversee production and installation. decoraciongrafica@ifema.es

Once the stand assembly is completed, any changes in the placement of elements that have not been communicated by the established deadline will be invoiced.

To **hire services**, you must do so through our online channel, which you can access via the following link.: [Commerce](#)



Free-Design Stands. Regulations and Assembly

Companies that choose to **build their own stands must upload the project to their Expo Zone for approval before 17 August 2026.**

If your project includes a rigging structure, you must complete the following application before August 17, 2026.

Assembly Fees

The company in charge of assembling the stand must pay IFEMA MADRID, before starting work, the assembly fees corresponding to the services provided during the assembly and disassembly periods of the fair. If the exhibitor wishes to assume the payment of these assembly fees and have them included in their invoice, they must contract it through the **Expo Zone.**

To be more efficient and provide better service, avoiding issues during the assembly, **IFEMA MADRID has started applying a late booking surcharge** for the assembly fees, as is the case with our other services.

This surcharge increases the price by **25%** when the booking is made during the week before (7 days prior) to the start of assembly, during assembly, the event, and disassembly.

We remind you that assembly fees apply to free-design stands and can be contracted with a **5% discount** if the booking is made up to **30 days before** the start of the fair assembly.

SPECIFIC ASSEMBLY REGULATIONS FOR FREE-DESIGN STANDS

Height

- Maximum authorized height for perimeter line: 4 m.
- To elevate or hang any decorative element to a maximum height of 6 m, it is necessary to set back 1 m inward along the entire perimeter.
- This option is not available in the connection cores between pavilions, nor on the side entrances of pavilions 9 and 10.
- Construction elements, decoration, and spotlights cannot protrude more than 50 cm from the allocated space and must have a minimum height of 2.5 m.

Height regulations

Maximum spatial occupation by any element.

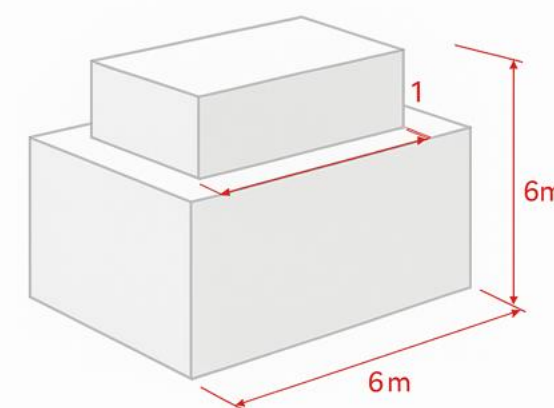

The interpretation and application of the regulations for each specific case is the responsibility of IFEMA MADRID, who reserves the right to grant exceptions if deemed necessary, based on maintaining the overall perspective of the event and the visibility of neighboring stands.

DESIGN YOUR STAND WITH US

In addition to turnkey stands, we offer a comprehensive stand design service, with our guarantee and fully tailored to your needs. We take care of the planning of your space, the design, the assembly, and the disassembly. Request, free of charge and with no obligation, a project tailored to your needs by sending an email to standbuilding@ifema.es

To hire services, please go through our online channel, which you can access through the following link: [Commerce](#).

1.7. Participation Fees

TYPE OF SPACE	RATE
Floor space only	133.70€/sq.m + VAT (1)
Floor+ Closed Modular Stand	200€/sq.m + VAT (1)
Floor + Open Modular Premium Stand	170€/sq.m + VAT (1)
Suelo + Stand Mini	2025€/sq.m + VAT (1)

SERVICES	RATE
Civil liability insurance (covers up to €60,000)	72,84€ + VAT (1)
Multi-fair insurance (covers up to €50,000)	69,15€ + VAT (1)
Minimum electricity consumption (0.16 kW/sq.m)	7,65€ + VAT (1)
ASSEMBLY RIGHTS	
Type A: Spaces without decoration or occupied by carpet or platform	2,77€/sq.m + VAT (1)
Type B: Basic modular stands made of aluminum or similar	5,56€/sq.m + VAT (1)
Type C: Modular design stands in aluminum, carpentry stands, and other materials	8,85€/sq.m + VAT (1)

CONNECT PLAN	450€ + VAT (1)
---------------------	----------------

1.8. Deadlines and Payment Methods

- **June 6, 2026:** Deadline for **the first 50% payment.**
- **July 24, 2026:** Deadline for payment of **100% of the contracted space and services**

PAYMENT METHODS

You can make the payment using the following methods:

Bank transfer to: IFEMA MADRID / Madridjoya 2026

Santander: IBAN ES64 0049 2222 5115 1000 1900 SWIFT: BSCHEM

BBVA: IBAN ES89 0182 2370 4000 1429 1351 SWIFT: BBVAESM

Caixa Bank: IBAN ES93 2100 2220 1102 0020 2452 SWIFT: CAIXESB

Please send a copy of the bank receipt to servifema@ifema.es

- Certified check, made payable to IFEMA MADRID/Madridjoya 2026.
- Credit card in a secure environment, accessible after completing the online participation application, or later through the Expo Zone. In accordance with current regulations, cash payments or bearer checks are not accepted.

In the Expo Zone, you will find your participation account status and invoices once the payments have been made. If you need an invoice to make a payment, please request it via email at servifema@ifema.es

Discounts:

- **10% discount** on the floor space fee for exhibitors participating for the first time or who have not participated in the last three editions.
- **5% discount** on services contracted through the Expo Zone, up to 30 days before the start of assembly, 18 August 2026.

This discount will also apply to services contracted by sending the floor plan of your stand to the technical secretariat. Mandatory minimum services such as outdoor advertising, meeting rooms, stand decoration and specific fair services such as exhibitor passes or invitations are not included.

- **2.5% discount** for early payment on the floor space rate **if you pay 100% of the contracted space before 6 June.** To request this, please contact Servifema at servifema@ifema.es and request an updated account statement.

Surcharges:

- **25% increase** for contracting services, including assembly fees, requested **7 days before the start of assembly**, 11th September 2026.

(1) Companies established in Spanish territory (excluding the Canary Islands, Ceuta, and Melilla): 10% VAT not included. For other companies, this operation is not subject to Spanish VAT. In the case of European Union companies, the exhibitor will be responsible for the VAT that may be due in their country of establishment.

1.9. Specific Participation Rules

The decision to accept the exhibitor will be at the discretion of IFEMA Madrid, taking into account the purpose of the fair and the availability of spaces. **The minimum area** for contracting is **9sq.m**.

The event management may alter the assigned spaces or make changes to the layout of the pavilions for organizational reasons. The event management reserves the right to change the location of the stands occupied by exhibitors from one edition to another if it deems it appropriate due to sectorization, product, or image reasons.

While the fair management will inform exhibitors in case of relocation or significant changes to the reserved location, each exhibitor is obligated to verify the location of their stand, its exact dimensions, etc. Access is not permitted to any exhibitor or visitor who cannot prove their affiliation with the professional groups participating, even if they hold the corresponding pass or invitation.

Exhibitors are required to attend their stand and keep the products on display during the entire event and opening hours. Failure to comply with this regulation may result in the loss of preferential renewal rights for the assigned space. Exhibitors are required to attend their stand and keep the products on display during the entire event and opening hours, so the removal of exhibition materials from the stand will not be allowed until the fair closes, especially on the last day, Sunday, September 27, 2026, until 16:00h.

The direct sale of any items exhibited at the fair is strictly prohibited, except in the Cash&Carry area. The exhibitor authorizes IFEMA MADRID to reproduce the products on display, in whole or in part, in its promotional material. The exhibitor agrees to comply with the environmental protection rules and guidelines.

Activities that may disturb other exhibitors are prohibited and should not exceed 60 decibels. Promotional activities, distribution, and display of samples, brochures, leaflets, and all types of promotional material must only be carried out within the exhibitor's space.

Any activities requiring the hiring of a catering service during the fair will require the completion of the "Communication for Catering in Stands" form, available on ifema.es, which must be submitted to: catering@ifema.es

It is expressly prohibited for exhibitors to install Wi-Fi access points, whether for internet connection or for the presentation of other functionalities. The purpose of this measure is to prevent interference issues, both with the points that each exhibitor could independently install and with the access points of IFEMA MADRID. Such interference could cause Wi-Fi networks to malfunction. For more information, you can consult Article 33 of the General Regulations for Exhibitors in Events Organized by IFEMA MADRID.

CANCELATION

The exhibitor's withdrawal from participation in the event results in the termination of the contractual relationship between IFEMA MADRID and the exhibitor for all purposes. The withdrawal must be communicated to the Event Management in writing and will result in the forfeiture of any amounts the exhibitor was due to pay by the date of communication, in accordance with the payment schedule outlined in the Participation Request.

If the withdrawal is communicated to the Event Management within 30 days prior to the event's opening, IFEMA MADRID may require the full payment of the contracted space.

Regarding additional services offered by IFEMA MADRID that the exhibitor has contracted prior to notifying the withdrawal, cancellation charges will apply as established in Article 7 of the general admission and contracting conditions for events organized by IFEMA MADRID.

In the event of the cancellation of the fair due to force majeure, the amounts paid for services related to physical participation will be refunded, in accordance with Article 15 of the **General Regulations for Participation** in events organized by IFEMA MADRID.

These Specific Rules, including the participation and assembly regulations in this chapter, complement the **General Regulations for Participation for Exhibitors in Events Organized by IFEMA MADRID**, which all exhibitors accept by virtue of their participation.

1. HOW TO PARTICIPATE. REGULATIONS

1.10. Exhibitor's Calendar

When	What	How	Who attends you
Until April 25, 2026	Application for participation in the priority period for space selection	Complete the application form to participate in the first allocation of space.	Contest management: madridjoya@ifema.es Customer service (Exhibitors): (+34) 917223000 atencionalcliente@ifema.es
From April 25, 2026	Participation application	Continuation of the process of receiving applications for participation.	Event management: madridjoya@ifema.es Customer service (Exhibitors): (+34) 917223000 atencionalcliente@ifema.es
Until June 6, 2026 Until July 24, 2026	Payments	<ul style="list-style-type: none"> - Until 6 June 2026: 50% of the cost of the space - Until 24 July 2026: 100% of the cost of the space and services contracted. <p>A 2.5% discount for early payment will be applied to the rate for the space occupied if you pay 100% of your participation fee before 6 June 2026.</p>	Servifema: servifema@ifema.es Customer service (Exhibitors): (+34) 917223000 atencionalcliente@ifema.es
Until August 17, 2026	Free design projects	Deadline for uploading free design projects to ZONE EXPO. If your project includes a rigging structure, you must complete the following application before August 17, 2026.	Technical Secretariat Line IFEMA MADRID Exhibitors (+34) 917223000 atencionalcliente@ifema.es
Until August 18, 2026	Services booking	Contracting services with a 5% discount	Technical Secretariat Line IFEMA MADRID Exhibitors (+34) 917223000 atencionalcliente@ifema.es
Until August 31, 2026 Until September 7, 2026	Customisation of modular stands Signage	<ul style="list-style-type: none"> - Present interior decoration projects for modular stands. - Please consult the modular stand project in the Expo Zone or upload it with the stipulated modifications. <p>Communicate signage through the Expo Zone of your stand's sign</p>	Line IFEMA MADRID Exhibitors (+34) 917223000 atencionalcliente@ifema.es

1. HOW TO PARTICIPATE. REGULATIONS

1.10. Exhibitor's Calendar

When	What	How	Who attends you
From September 11, 2026	Contracting of services	25% increase on prices for last-minute contracting of assembly rights and other services.	Line IFEMA MADRID Exhibitors (+34) 917223000 atencionalcliente@ifema.es
From September 18 to 22, 2026	Stand Assembly	<ul style="list-style-type: none"> - 18 September from 8:30 a.m. to 9:30 p.m. - 19 and 20 September from 8:30 a.m. to 7:30 p.m. - 21 and 22 September from 8:30 a.m. to 9:30 p.m. 	-
September 23, 2026	Delivery of Modular Stands	23 September from 8:30 a.m. Exceptionally, and upon express request to Madridjoya@ifema.es , access with decorative materials or machinery will be authorized if required on Tuesday, September 22 .	Pavilion manager
September 23, 2026	Goods Entry	September 23 from 8:30 a.m. to 9:30 p.m. From 7:00 p.m. onwards, entry will only be possible through the pedestrian doors, as the goods gates will be closed to allow for the installation of recyclable carpet in the aisles.	Pavilion manager
From September 24 to 27, 2026	Celebration of the fair	<ul style="list-style-type: none"> - 24th, 25th, and 26th from 10:00 a.m. to 7:00 p.m. - 27th from 10:00 a.m. to 4:00 p.m. 	-
September 27, 2026	Goods Exit	Hours: from 4:30 p.m. to 10:00 pm.	Pavilion manager
September 28, 2026	Dismantling of stands	Hours: From 6:00 am to 00:00 am.	Pavilion manager

2. MANAGE YOUR PARTICIPATION

Madridjoya

2.1 Expo Zone. Manage your participation and your space. Contracting additional services. E-commerce

Access our customer area Expo Zone from the web: www.ifema.es/madridjoya to manage your company data, your contacts and everything related to your participation. You will be able to access your participation once you have confirmed your participation with your user (the e-mail address you used to fill in the Participation Request).

What can I do from Zona Expo?

- Access the details of each participation, plans and projects
- Access the exhibitor's calendar.
- View documents of interest.
- Manage exhibitor passes and request visa support letters.
- Download discount vouchers: Renfe, Iberia.
- Send invitations.
- * Send Club Cards
- Access orders, payments, account status and invoices issued.
- Upload free design stand projects.
- Request the distribution of elements of modular stands, coat racks or shelves, add the sign and choose the color of the carpet.
- Access to e-commerce for the contracting of services.

(1) Companies established in Spanish territory (excluding the Canary Islands, Ceuta, and Melilla): 10% VAT not included. For other companies, this operation is not subject to Spanish VAT. In the case of European Union companies, the exhibitor will be responsible for the VAT that may be due in their country of establishment.

2.2 Exhibitor passes, transport discount vouchers, visas and invitations

EXHIBITOR PASSES

Exhibitor passes will be managed from ZONA EXPO, in the section "Access to the event/Exhibitor passes".



Each exhibitor will be assigned passes based on the contracted surface area (2 passes for every 5sq.m , up to a maximum of 50 passes). In order to ensure professionalism at the fair, all exhibitor passes will be personalized: they will include the name of the pass holder, company, and country. To prevent misuse, identity checks may be carried out at the fair's entrances.

Exhibitors can request additional exhibitor passes free of charge by sending an email to madridjoya@ifema.es

Both exhibitor and professional visitor passes allow access to the fair during all the event days and to any of the coinciding halls, BISUTEX, MADRIDJOYA, and MOMAD



Tipo de pase	Personalización	Duración	Disponibles	Generados
<input type="radio"/> Pases de expositor	Genéricos	Feria	0	5

[Solicitar Carta Apoyo Visado](#) [Generar](#) [Adquirir Pases Adicionales](#)



2. MANAGE YOUR PARTICIPATION

ONLINE INVITATIONS

Free Professional Invitations: Unlimited invitations per exhibitor. Professionals who receive these invitations must register online by entering the provided code to obtain their free pass for direct access to the fair, avoiding unnecessary queues.

Online registration will be available until September 27, 2026.

Additionally, all exhibitors have the option to use Printed Professional Invitations, with a distribution of 1 invitation per sq.m , up to a maximum of 500 per exhibitor, which will be delivered by messenger. This type of invitation also requires the visitor to complete the online registration process using a promotional code.

CLUB Cards: These include direct access to the fair for the holder and one companion, as well as one day of free parking. Based on the contracted surface area, each exhibitor will receive the following number of CLUB Cards for their buyers:

- Less than 30 sq.m : 10 guests
- 30 to 50 sq.m : 20 guests
- 50.5 to 100 sq.m : 35 guests
- More than 100 sq.m : 50 guests

The sending of invitations will be carried out through "ZONA EXPO/Access to the event/Invitations/Manage Invitations.

The following screen will appear to customize the shipment:

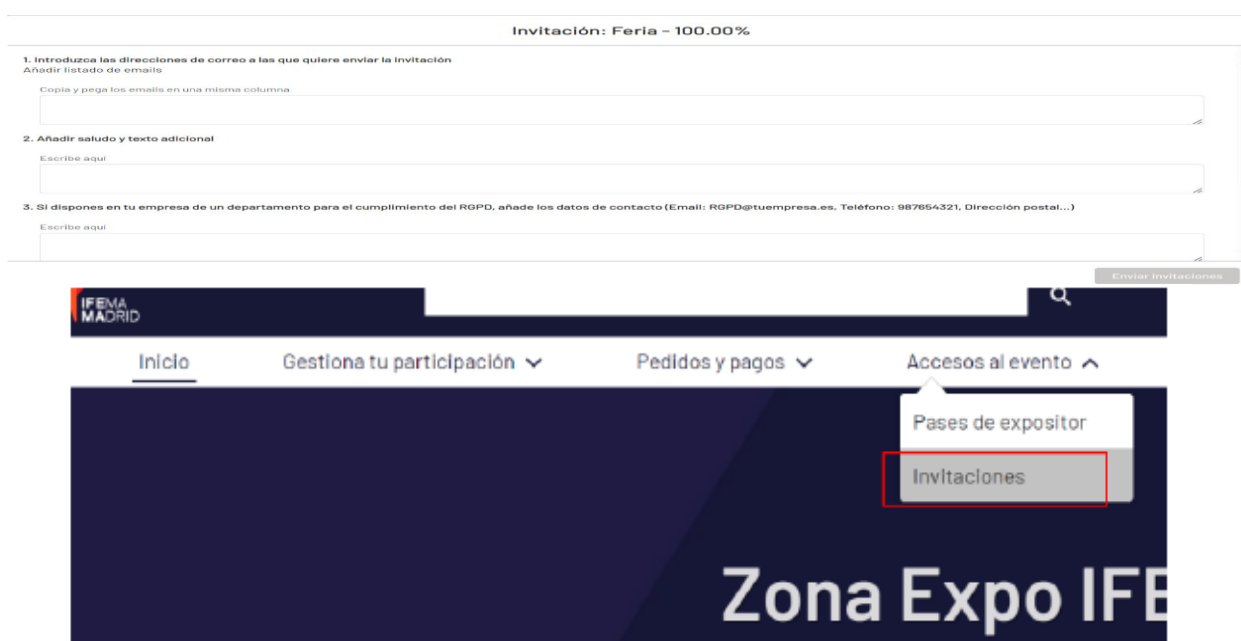

We urge exhibitors to make proper use of the invitations by sending them exclusively to industry professionals to ensure the professionalism of the fair. Access controls may be implemented for this purpose. Professionals who receive the invitation code must register ONLINE through the website <https://www.ifema.es/madrid-joya>, in the "Get your pass" section, and enter the invitation code received to obtain their pass for free to access the fair. (Invitation codes cannot be redeemed at the counter).It will be absolutely necessary for all Professional Visitors who are accessing the venue with a Professional Invitation to be accredited as Professionals through <https://www.ifema.es/madrid-joya>

VISA MANAGEMENT

If you require a visa to travel, **you can request the support letters for visa processing directly from ZONA EXPO.** To do this, you **must first personalize your exhibitor pass** and **complete the payment** for your participation, following the payment schedule (see point 1.8).Once these two requirements are met, you can access the "Request visa support letter" button from ZONA EXPO/Access to Event/Exhibitor Passes. We advise that you start the process as soon as possible, as the visa application deadline is usually at least 30 days before traveling.



TRANSPORT DISCOUNT VOUCHERS

Once exhibitor passes have been requested, **the corresponding transport discount vouchers can be downloaded from ZONA EXPO**, under the section "Manage Your Participation/Documents."

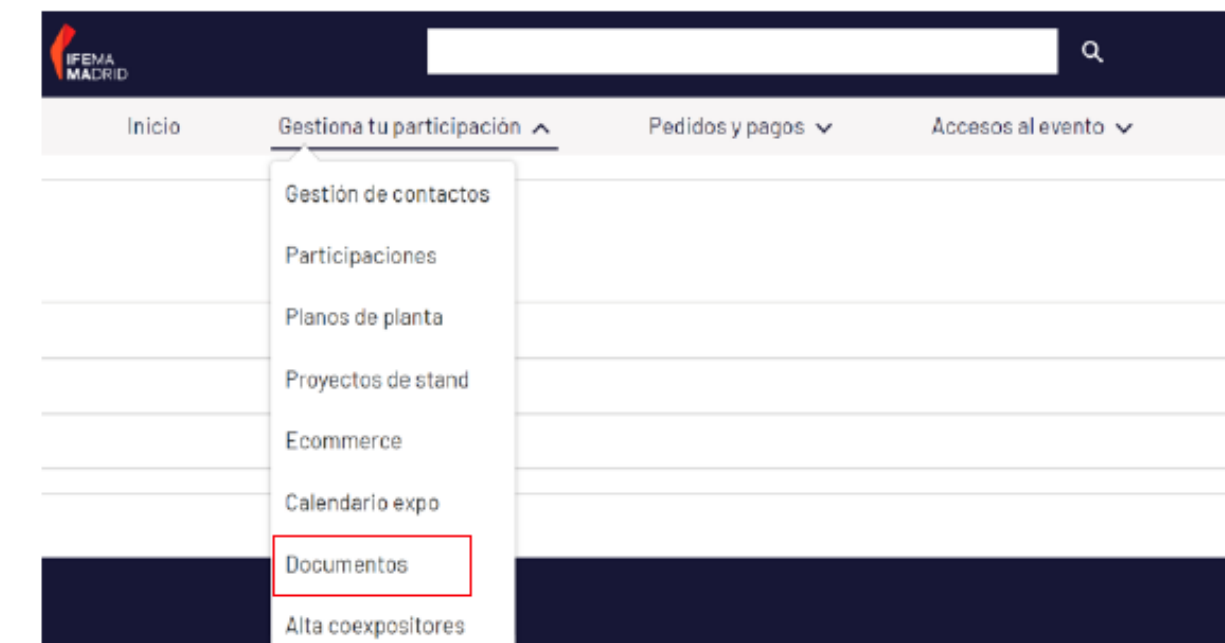

Other relevant information

Shipment of goods to the site

IFEMA MADRID staff is not authorized to receive any goods destined for your stand. To send goods to the venue the exhibitor must indicate in the delivery address:

- IFEMA MADRID (Avda. del Partenón, 5. 28042 Madrid. Spain)
- Feria Madridj oya
- Name of your company.
- Pavilion and stand number.

The goods must be received by your company's staff at your stand and arrive during the days set aside for the entry of goods and decoration.

In case it is not possible to comply with the above, we recommend you to contact our partner company for goods management (handling and warehousing):

- ♦ Oficina de DSV en Recinto Ferial de IFEMA MADRID: Pabellón 7
- ♦ Teléfonos: 659 271 676 / 682 191 672
- ♦ angelica.gheorghe@dsv.com; luis.quintana@dsv.com

CUSTOMS REGULATIONS

1. All products coming from non-EU countries must go through customs procedures, with special mention to the fact that since January 1, 2020, the United Kingdom has been treated as a third country, so all shipments originating in the United Kingdom must regularize their merchandise through the corresponding customs procedure.
2. Exhibiting companies must have the details of the customs agent who carries out the clearance of their goods or, failing that, a copy of the customs documentation of entry into the European Union.

3. The material or goods for distribution or consumption must pay Spanish taxes, even if they are products with no commercial value (depending on the country, the amount of taxes may vary).

4. All goods subject to a temporary regime must not be moved from the stand or leave the IFEMA MADRID Exhibition Center until their situation has changed and customs formalities have been completed. It may only be deposited during these procedures in the warehouse of the official logistics agent within the Fairgrounds.

It is strictly forbidden to exhibit, sell, consume or distribute non-Community merchandise at a trade fair before the customs procedures have been completed. This includes promotional material.

6. Products that are transported as hand luggage must be declared at Barajas Airport in the RED CHANNEL ("Something to declare") and must regularize the merchandise with the corresponding authority at the airport.

7. Goods that have not passed customs control and are on display will be confiscated by the customs authorities operating at the Fairgrounds until the appropriate documents are presented.

Any truck arriving at IFEMA MADRID under a transit consigned to IFEMA MADRID, must go to the warehouse of the official Logistics Operator, for the regularization of the goods transported, located at:

Avenida Partenón s/n

Entrada Oeste - acceso calle Rivera del Sena

Pabellón de servicios nave 2

28042 Madrid

In order to avoid unwanted situations, and for any questions that may arise, you can contact our Customs Logistics Operator, DSV: (+34)659271676, (+34)682191672; email: angelica.gheorghe@dsv.com; luis.quintana@dsv.com

CATERING AT THE STAND

Los expositores que vayan a ofrecer, con carácter gratuito, restauración/catering en su stand, deberán cumplimentar el formulario.

[<comunicación para la realización de restauración/catering en stands>](#)

Disponible en la web de IFEMA MADRID y remitirlo con todos los datos solicitados a catering@ifema.es

PARKING CATERING / REFRIGERATED TRUCKS

There is a parking area for catering vehicles and refrigerated trucks, with the possibility of electrical connection. You can hire it through the [eCommerce](#)

DAILY REPLENISHMENT OF GOODS

There is the possibility of introducing goods in an interrupted way through the service doors, located at the back of the pavilions. Later on we will inform you about the patterns enabled for this purpose and the schedules for the daily replenishment of goods.

ROOM RENTAL

For the exhibitors of the event, there is the possibility of renting rooms at the venue if you wish to prepare a conference, reception, press conference or product presentation during the fair. It is necessary to make a reservation in advance. Request an estimate without any kind of commitment via email uanproduccion@ifema.es

[MORE INFORMATION](#)

2. MANAGE YOUR PARTICIPATION

2.5 Site plan



2.6 Frequently Questions

Question	Answer
Where can I consult the IFEMA MADRID General Rules of Participation to which my participation is subject?	In addition to the Exhibitor's Guide, participation in Madridjoya is subject to IFEMA MADRID's General Rules of Participation, which you should be informed about and which you can access on the IFEMA MADRID website (www.ifema.es) and via the following link IFEMA MADRID General Rules of Participation .
Can I hire a catering service or serve my own food and beverages at the stand?	<p>Yes. Exhibitors who are going to offer a catering service at their stand (free of charge), can do so either by submitting their application with the approved catering companies at IFEMA MADRID (See the list HERE) or through other catering service providers, in which case it is essential to fill in the form "Notification for the provision of catering services on stands" available in the exhibitors' area of the institutional website and send it, with the information requested therein, to: catering@ifema.es for its information and appropriate ends.</p> <p>If IFEMA MADRID has not been notified, the Exhibitor will not be able to offer this service on their stand. The Exhibitor assumes responsibility for third-party complaints that are caused by said catering service and expressly exempts IFEMA from any liability in this regard.</p>
Can I access the trade fair centre with vehicles for assembly and disassembly or loading and unloading of goods?	<p>Access to IFEMA MADRID and to the inside of the halls will be done through the doors and on the days and times stated in this Exhibitor's Guide. The inside of pavilions will only be accessed to unload materials. Vehicles will not be able to park inside the halls or in the adjacent areas. We would like to remind you that, for safety reasons, it is strictly forbidden to park directly in front of the goods entrance.</p> <p>IFEMA MADRID takes no responsibility for the surveillance of vehicles while they are on the grounds of Feria de Madrid.</p> <p>There is a car park for trucks and another for private cars, which can be used by paying, where appropriate, the corresponding fees. Check rates</p>
Can I have a vehicle on my stand?	Vehicles with a combustion engine used as part of an exhibition display must have a tank filled with the minimum fuel required to access the allocated space and be able to leave it at the end of the exhibition.

2.6 Frequently Questions

Question	Answer
<p>Can I send merchandise to my booth?</p>	<p>IFEMA MADRID staff is not authorized to receive goods for your stand. To send goods to the venue, the exhibitor must indicate the following delivery address: IFEMA MADRID (Avda. del Partenón, 5. 28042 Madrid, Spain). Madridjoya Fair. Your company name. Hall and stand number.</p> <p>The goods must be received by your company staff at your stand and should arrive during the designated days for goods delivery and decoration. If it is not possible to meet these requirements, we recommend contacting the goods management partner company: DB Schenker Office at the IFEMA MADRID Exhibition, Center: Hall 7, (+91) 330 51 77 ifema.madrid@dbschenker.com</p>
<p>What procedure do I have to follow to hang structures on the pavilions/rigging?</p>	<p>Exhibiting companies may hang elements from the ceiling of the halls following the procedure shown in the "Regulations for hanging structures in Halls" and by completing the form "Application for authorisation for hanging structures/rigging" and sending it to: inspección.rigging@ifema.es</p>
<p>Can I hold prize draws and raffles at the stand?</p>	<p>Raffles, prize draws, and random combination games are forms of gambling as set out in articles 3.2 and defined in article 15 of Law 6/2001 of 3 July on gambling in the Community of Madrid.</p> <p>All the information is available in the following form: https://sede.comunidad.madrid/comunicaciones-declaraciones/cifras-tombolas</p>
<p>How do I apply for a visa support letter?</p>	<p>Visa support letters are managed through the EXPO ZONE. To do so, you first have to personalise your exhibitor passes. Once you have managed your exhibitor passes, you can request your support letters and download them to your computer.</p> <p>It is essential to be up to date with payments according to the payment schedule in order to be able to apply for the letters.</p>
<p>Where can I hire the services of my booth?</p>	<p>Accessing the E-commerce found within the EXPO ZONE or through the link: https://shop.ifema.es</p>
<p>Who should I contact to hire a room?</p>	<p>Incumbent exhibitors who need to hire a room should contact: uanproduccion@ifema.es</p>

2.6 Frequently Questions

Question	Answer
<p>What does the CONECTA PLAN include?</p>	<p>This concept of compulsory contracting includes the following services:</p> <ul style="list-style-type: none"> - Dissemination of the participation in the fair through the insertion in the list of exhibitors accessible in open access on the fair's website and shared in communications. - Presence during the celebration of the fair in the pavilion plans and exhibitors' lists. - Presence as exhibitors in the digital event of the fair Madridjoya liveconnect with 10 products or services associated with the company file - Access to the customer portal "ZONA EXPO" of IFEMA MADRID to manage participation. - Exhibitor passes according to the contract (see point 2.3) - Online invitations according to the contract (see point 2.3) and delivery service through ZONA EXPO - Discount vouchers for transport. - Premium wifi connection for 3 users during the entire fair (5 GHz devices). Access keys will be sent the days prior to the start of the fair. - Access to Madridjoya liveconnect for 3 users with connection functionalities to generate business opportunities.
<p>How to use the EXPO ZONE?</p>	<p>In the Next video a tutorial on how to use the EXPO ZONE is shown.</p>
<p>What are the benefits of my Expo Zone?</p>	<p>It is used to manage the participation of each exhibiting company in Madridjoya</p> <ul style="list-style-type: none"> • Registration of contacts that will access the Expo Zone and management of access permissions • Access to the exhibitor's calendar. • View documents of interest. • Manage exhibitor's passes, request visa support letters and send invitations. • Register co-exhibitors. • Access to payments, statement of accounts and invoices issued. • Upload free design booth projects and distribution of modular booth elements. • Add the sign and choose the color of the carpet for exhibitors with modular booths. • Access to e-commerce for the contracting of services.

2.6 Frequently Questions

Question	Answer
What are the utilities of my liveconnect?	<p>In the exhibitor area of my company in liveconnect:</p> <ul style="list-style-type: none">• Update the company data visible in the catalog and Madridjoya liveconnect .• Display the offer of products and services.• Manage the company's appointment schedule for professional meetings at the stand.• Register other team members with access to liveconnect. <p>At the fair in liveconnect:</p> <ul style="list-style-type: none">• Complete my personal profile on the platform and my agenda of availability for meetings.• Search for contacts of interest in the professional network and request and agree to be a contact for chat and videoconferences.• Scan professional visitor passes at the fair.• View information about the offer of other exhibitors.• Consult the activities with the possibility of scheduling them and viewing the digital content available.
How can I request my invoices?	<p>Invoices are not generated by default. You must request them directly to the IFEMA MADRID invoicing department (servifema@ifema.es) indicating the fair where you are exhibiting and the concepts to be included in the invoice. Once it has been generated, it will be available in your Expo Zone.</p>
What is the difference between the space only option and the turnkey modular booth option?	<p>The space-only modality includes only the contracting of the space and the compulsory elements (insurance, minimum electricity consumption and CONECTA EXHIBITOR PLAN, and it is the exhibitor who has to create a free-design stand or contract it through the stand design service offered by IFEMA MADRID.</p> <p>Modular stands are delivered assembled. See description in section 1.6</p>

2.6 Frequently Questions

Question	Answer
Can I decorate and/or set up my stand with IFEMA?	<p>Yes, IFEMA MADRID offers two main services:</p> <p>Graphic decoration for stands: Customize your modular stand with your brand image, generating maximum impact on visitors. There is a wide range of versatile graphic materials adaptable to walls, furniture, fronts, banners... You can request information and a quote at decoraciongrafica@ifema.es</p> <p>Stand design: consists of a comprehensive stand design service fully adapted to your needs. From the planning of your space, design, assembly and disassembly. You can request information and budget at standbuilding@ifema.es</p>
Is it mandatory to attend the booth at all times?	<p>Yes, the exhibitor is obliged to attend its stand and remain with the products exhibited during the entire period and opening hours of the show.</p>
Are rigger's passes required during the assembly/disassembly of the fair?	<p>No. The requirements to be able to ride are to have paid 100% of your participation, to have presented and approved the project, to have paid the assembly fees, and to have completed the occupational risk protocol.</p>
How to hire parking at IFEMA?	<p>Exhibiting companies will be able to contract parking spaces from e-commerce, which is located inside the Expo Zone or through the link https://shop.ifema.es</p> <p>Once the contract has been made, parking badges can be picked up from September 18 (first day of assembly) at the exhibitor service desk, located in the central boulevard between pavilions 6 and 8.</p>

2.6 Frequently Questions

Question	Answer
What coverage do I have as an exhibitor with the insurance included?	You can consult the coverage of the compulsory insurance policies in the IFEMA MADRID exhibitor support area .
How can I access the WI-FI network as an exhibitor?	As an exhibitor you will receive as part of the CONNECT PLAN a Wi-Fi connection for 3 users during the entire trade fair for the exclusive use of stand holders. Devices that allow 5GHz network capability are required. Access codes will be sent out during the lead up to the event. Additional Wi-Fi access can be booked through the e-commerce section inside the EXPO ZONE or via the link https://shop.ifema.es
Regulations and support for exhibitors at the trade fair centre	https://www.ifema.es/en/support/exhibitors-ifema-fairgrounds
Regulations and support for fitters at the trade fair centre:	https://www.ifema.es/en/support/assemblers-colaborators-fairgrounds

3.1 How to monetize my participation

- Prepare complementary promotional activities to your participation prior to the fair to enhance and get the most out of your investment.
- Send your customers the personalized communication sent by the fair by e-mail, with your company name and access to online registration.
- Use the social media creativities that we provide to advertise your presence at the fair indicating your company name and booth number. These elements will be available in the Expo Zone.
- Use promotional elements sponsored with your logo or brand image: badge lanyards, other specific elements defined by your company to hand out to visitors: madridjoya@ifema.es
- Hire outdoor showcases with high visibility, located at the entrance of the pavilions: madridjoya@ifema.es
- Hire other Advertising Services and Promotional Elements by contacting publicidad@ifema.es or by phone (+34) 91 722 53 08/40.
- Contract other optional Promotional Elements and Services focused on increasing the visibility of your brand, before, during and after the event, before August 12, 2026:
 - Banners
 - Advertising on the platform
 - Sponsored newsletters
- Communicate the news you will present at the fair to our Social Media Agency, Annie Bonnie (ifema@anniebonnie.com) and/or our Press Department, Pablo López (plopez@ifema.es) and Selva Dalila (sdalila@ifema.es)

Additionally, we invite you to follow us on social media and share our content to boost your own social networks. The official hashtag is #madridjoya2026. Invite your clients by sending them:

- **Free professional**
- **Invitations Club**
- **Cards Personalized communications**

Image Forum and Catwalk: contact madridjoya@ifema.es to propose activities of interest and/or participate in this space.

On the IFEMA MADRID website ifema.es/soporte, you will find a list of other services, regulations, and documents that may be of interest to you:

- Regulations and conditions for catering at stands
- Occupational risk prevention and business activity coordination
- Request for private security authorization at stands
- Request for authorization to hang structures/rigging

3.2. Exhibitor Catalogue

The fair's catalogue is a key tool for promotion and contact. It allows visitors and exhibiting companies to access your information before, during, and after the event.

- **Update your details:** Include your contact information, products or services, and any relevant details to maximize your company's visibility.
- **Digital management:** All communication regarding your participation is managed through liveconnect.
- **Take advantage of the platform:** Use all its features to communicate your presence, schedule meetings, and connect with your target audience.

3.3. Visitor Guide

Madridj oya produces a visitor guide that is distributed for free at the pavilion information points.

3.4. Networking

liveconnect allows you to search for and connect with other participants using filters such as country, activity, position, or products of interest.

- **Find potential clients** and request contact by sharing your email and phone number.
- **Connect and schedule** meetings once your request is accepted, either at the fair or via videoconference.
- **Be proactive** and create your own list of strategic contacts.
- **Receive meeting requests**, both at the company level and individually for your team.
- Plan your schedule in advance and optimize your opportunities at the fair.

3.5. Invitations for your clients and contacts

IFEMA provides you with access invitations to the fair so you can promote your participation efficiently. Be sure to use this useful tool available to you in your Expo Zone.

3. PROMOCIONE Y RENTABILICE SU PARTICIPACIÓN

Madridjoya

3.6. Buyers Program

National and international buyers program. Please send the corresponding file, which you will receive by email, to Ana Belén Cisneros (hb.ifema@ifema.es)

before July 20, 2026.

- National buyers:
 - Less than 25 sq.m : 3 invitations
 - From 25 to 100 sq.m : 5 invitations
 - More than 100 sq.m : 7 invitations
- International buyers:
 - Less than 25 sq.m : 2 invitations
 - From 25 to 100 sq.m : 4 invitations
 - More than 100 sq.m : 6 invitations

3.7. Publish your news and updates. Social Media and Website

Additionally, we invite you to follow us on social media and share our content to boost your own social networks. The official hashtag is

#Madridjoya.

3.8. Outdoor and Digital Advertising

Here's the translation of your text into English:

Advertising projects tailored to your needs:

- Promote your brand before, during, and after the event
- Attract new customers through the best B2B market segmentation

More information here: [Advertising | IFEMA MADRID](#)

Also, check out the advertising options available on the liveconnect platform.del mercado.

3.9. Sponsorships

You have access to a wide range of promotional and sponsorship opportunities that will provide outstanding additional visibility and allow you to carry out high-impact actions targeted at the national and international professional audience attending the fair.

FOR SPONSORSHIP OPPORTUNITIES, CONTACT: patrocinios@ifema.es

3.10. Special Promotional Actions

IFEMA offers its clients special marketing actions to optimize the impact of their presence at the venue.

Contact: publicidadexterior@ifema.es | Tel.: (+34)91722 53 08/40.

3.11. Workshops, Demonstrations, and Seminars at the Fair

The fair features a comprehensive program of activities, talks, panel discussions, and conferences designed to provide companies with a platform to share specific content or present their products and services. Promote your content or showcase your products and services.

3.11. Room Rental

For event exhibitors, there is the option to rent rooms at the venue if you wish to organize a seminar, reception, press conference, or product presentation during the fair. Early reservation is required. Request a quote:

(+34) 91 722 30 00

uanproduccion@ifema.es

[Link to Room Navigator](#)



4. SUSTAINABILITY MANAGEMENT AT IFEMA MADRID

Madridjoya

At IFEMA MADRID we are not only fully committed to sustainability per se, but also, to achieving the sustainable development goals (hereinafter SDGs) promoted by the United Nations, which we have incorporated into our strategic corporate management policy and culture.

IFEMA MADRID's sustainability policy is mainly focused on the following SDGs: 8, 9, 11, 12, 13, 16 and 17.

ISO Standards certified by IFEMA MADRID:

- ISO 9001: Quality Management,
- ISO 20121: Event Sustainability Management.
- ISO 14001: Environmental Management,
- ISO 50001: Energy Management,
- ISO 22320: Emergencies Management..

ACTIONS TAKEN AT IFEMA MADRID TO REDUCE GAS EMISSIONS AND BE MORE ENERGY EFFICIENT:

- 100% certified electrical energy of renewable origin.
- Geothermal installation in Puerta Sur building.
- Low consumption lighting in our halls and on our modular stands.
- Controlling the temperature of our air-conditioning / HVAC systems.

IFEMA MADRID is in possession of "calculo" (I calculate) and "reduzco" (I reduce) stamps in Carbon Footprint Scopes 1 and 2.

WASTE MANAGEMENT:

- The exhibitor/assembler is the generator of the waste and shall therefore be responsible for its removal and management. How the waste generated by the exhibitor is managed is explained in article 35 of the General Rules of Participation.
- We offer our exhibitors a service that includes the removal and management of the waste they/their assemblers generate. (check our fees in Exhibitors' Area).

CARPET RECYCLING:

IFEMA MADRID recycles 100% of the carpeting used in aisles and communal areas. To do so it has been essential to change our assembly and disassembly process, that affects the entry and removal of goods (check the corresponding item). Furthermore, means that it has to be laid in strips instead of covering the entire surface area as was previously the case. This means we can guarantee its conversion into a new raw material for the subsequent manufacture of other products.

SUSTAINABLE MOBILITY:

IFEMA MADRID offers access to public transport close to its facilities (metro and bus), parking for electric cars with 100% renewable electricity charge points, as well as a parking area for bicycles and scooters.

GUIDE TO SUSTAINABLE PARTICIPATION IN TRADE FAIRS/EVENTS:

IFEMA MADRID has published its Guide to Sustainable Participation in Trade Fairs for exhibitors on its website. We recommend you read it before starting to prepare your participation: ifema.es/en/about-us/quality-sustainability



5. CONTACT US

Department	Ask us about	Contact		
Address evento	<ul style="list-style-type: none"> Space Rental General topics of participation in the fair Exhibitor passes Professional visitor invitations Activities and forums at the fair 	Director	Julia González	(+34) 91 7223000 madridjoya@ifema.es
		Comercial Manager	María Terrón	
Customer Service IFEMA MADRID	<ul style="list-style-type: none"> Service Hiring Expo Area Visitor Information 	Administrative:	Maribel Moreno	(+34) 91 722 30 00 atencionalcliente@ifema.es
Technical Secretariat(Fair Services Department)	<ul style="list-style-type: none"> Technical support tasks for exhibitors and contractors Review of stand construction projects Solutions to technical problems during the fair Customization of modular stands Coordination for stand catering services 	(+34) 91 722 30 00 stecnica@ifema.es		
Graphic Decoration	Hiring of graphic materials to personalize your stand	(+34) 91 722 30 00 decoraciongrafica@ifema.es		
Comprehensive stand design service	Design and construction of custom-designed stands	(+34) 91 722 30 00 standbuilding@ifema.es		

5. CONTACT US

Department	Ask us about	Contact
Publicidad Exterior	Hiring of Advertising Media at the Fairgrounds	(+34)91 722 53 40/08 publicidadexterior@ifema.es
Communication and Marketing Department	Relations with the Media	<div style="display: flex; justify-content: space-between;"> <div> <p>Director: Raúl Díez Comunication Director: Nuria de Miguel Head of Press: Pablo López Press: Selva Dalila International Press: Elena Valera Press Secretary: Pilar Serrano</p> </div> <div> <p>(+34)91 722 50 93 plopez@ifema.es sdalila@ifema.es prensa@ifema.es</p> </div> </div>
Planning and Control Department	<ul style="list-style-type: none"> Rental of various meeting and convention spaces at the exhibition venue, both during and outside of the fairs. Coordination of off-fair activities. 	(+34)91 722 30 00 uanproduccion@ifema.es
Institutional Relations (Protocol)	<ul style="list-style-type: none"> Institutional visits Guided tours Protocol for all events Institutional relations 	(+34)91 722 30 00 infoifema@ifema.es
Security and Self-Protection Department	<ul style="list-style-type: none"> General security and parking Access to the Exhibition Park 	(+34)91 722 50 65 dseguridad@ifema.es stecnica@ifema.es
Medical Service and Security Emergencies	<ul style="list-style-type: none"> Medical emergency Healthcare for exhibitors and visitors during the fairs, setup, and dismantling 	(+34)91 722 54 00

Gracias

