

GLOBAL MBLTY CALL

Sustainable Mobility
World Congress & Expo

09-11
Jun
2026

Connecting the
sustainable mobility
ecosystem.

Sponsored by:



In cooperation with:



INDEX

1. HOW TO PARTICIPATE

- 1.1 Dates, schedule, and venue. Invited sectors
- 1.2 What do I need to do to participate?
- 1.3 Space allocation and contracting
- 1.4 Participation options
- 1.5. LIVE Connect: the digital platform accessible with your exhibitor plan
- 1.6. Your space at the fair. Stand types
- 1.7 Participation fees
- 1.8 Deadlines and payment methods
- 1.9 Specific fair regulations
- 1.10 Exhibitor calendar

2. MANAGE YOUR PARTICIPATION

- 2.1 Expo Zone. Manage your participation and space. Additional services contracting. E-commerce
- 2.2 Registration of co-exhibitors
- 2.3 Exhibitor passes and invitations. Visas. Vouchers and discounts
- 2.4 Other relevant information
- 2.5 Map
- 2.6 FAQs

3. PROMOTE AND MAXIMIZE YOUR PARTICIPATION

- 3.1 Exhibitor Catalogue
- 3.2 Networking
- 3.3 Invitations for your clients and contacts
- 3.4 Outdoor advertising

4. SUSTAINABILITY MANAGEMENT AT IFEMA MADRID

5. CONTACT US

1.1 Dates, Schedule, and Venue. Invited Sectors

Global Mobility Call will take place at the IFEMA MADRID fairgrounds **from June 9 to 11, 2026** from 9:00 am to 6:00 pm and the last day from 9:00 am to 3:00 pm.

Exhibitors will be able to access the venue from 8:30 am and leave it before 6:30 pm.

The virtual event through the digital platform will be open from 15 February to 1 September 2026

The character of the fair is professional.

Sectors convened:

ASSOCIATIONS, ORGANIZATIONS AND PUBLIC ADMIN.

SPECIALIZED PRESS

AUTOMOTIVE

SERVICES MOBILITY

ENERGY FOR SUSTAINABLE MOBILITY

SMART URBAN & RURAL MOBILITY

PUBLIC TRANSPORT & MULTIMODAL URBAN MOBILITY

IoT, DATA ANALYTICS AND CYBERSECURITY

AEROSPACE MOBILITY

LAND MOBILITY

MARITIME MOBILITY

LOGISTICS AND DISTRIBUTION OF GOODS

INFRASTRUCTURES FOR MOBILITY

SUSTAINABILITY AND ENVIRONMENT

SAFE, INCLUSIVE AND ACCESSIBLE MOBILITY

1.2 What Do I Need to Do to Participate?

To apply for participation, you must complete the **Participation Request Form** online, available on the fair's **website** within the established deadline, and submit proof of payment for the reservation fee.

Submitting the Participation Request implies full acceptance of **the General Participation Rules** for events organized by IFEMA Madrid, the technical annexes, the specific rules for this edition, and any general or specific provisions established by the fair organizers.

The exhibiting company is the company in whose name the application to participate as an exhibitor is completed.

In order to apply to participate in the fair, it is an essential requirement that the activity of the company, public or private entity, is included in the sectors covered by the fair within the sectors covered by the fair.

By clicking on the send application button, the exhibitor confirms to IFEMA MADRID that he/she is seriously interested in participating in the fair.

MADRID that it is seriously interested in participating as an exhibitor and in receiving a proposal.

The decision to accept the exhibitor will be at the discretion of IFEMA MADRID taking into account the purpose of the fair and the availability of space. IFEMA MADRID will make one or more proposals for space/location depending on the type of depending on the type of participation and/or type and size of stand requested.

This proposal constitutes a contract offer. If the contracting party accepts the offer/quote in writing/email/signature or during a site selection meeting, the contract for participation in the fair is concluded.

1.3 Space Allocation and Contracting

The decision to accept the exhibitor will be at the discretion of IFEMA Madrid, taking into account the purpose of the fair and the availability of space.

IFEMA Madrid will make one or more space/location proposals depending on the type of participation and/or type and size of stand requested. This proposal constitutes a contracting offer. If the contractor accepts the offer will be formalizing the contract for participation in the fair, which is a binding commitment and not revocable by the applicant.

The space will be awarded upon acceptance, in writing, by the exhibitor.

The exhibitor will receive the exhibition contract with the statement of accounts and a plan of the location and dimensions of their stand/s and will then be able to access the Zona Expo customer portal to manage their participation.

It is essential to make the payments indicated in the contract within the established deadlines.

1.4 Participation modalities and exhibition areas.

- **Exhibitor:** is the natural or legal person, which has space at the fair. The exhibiting company is the company in whose name the application to participate as an exhibitor is completed.

The exhibitor has the option of contracting a 'basic turnkey stand' or contracting only the space to build his own 'free design stand'.

- **Co-exhibitor:** an individual or legal entity that participates in the stand of an exhibitor, contracting directly with him. The exhibitor must register their co-exhibitors from the customer portal Zona Expo and each co-exhibitor must complete an application for participation as a co-exhibitor at the fair.

- **Partner:** individual or legal entity that participates in the congress as a sponsor of the congress.

1.5. CONECTA Exhibitor Plan: The Digital Platform Accessible with Your CONECTA Exhibitor Plan

Conecta Exhibitor Plan

Participation as a regular exhibitor at the fair requires the contracting of the CONECTA EXHIBITOR PLAN €541 + VAT (1)

**This concept includes the following services:
Mandatory in all modalities*€541 + VAT (1)**

*Included in the sponsorship packages (Global, Strategic and Focus Partners) and Startups.

- Access to digital platform for networking and innovation.
- Information Points in celebration: located in different strategic points. Accessible to visitors, with the possibility of searching for exhibitors and printing individualized location maps.

- Newsletters from GLOBAL MOBILITY CALL.
- RRSS from GLOBAL MOBILITY CALL.
- GLOBAL MOBILITY CALL Press News Repository.
- WIFI: 20MB / 5Ghz band /3 users / technical support.
- Discount vouchers Renfe and Iberia.

In the event that the exhibitor contracts his stand after the closing date of each of the elements, being impossible to be included in them, he will also be obliged to pay €541 + VAT (1).

- Access to IFEMA MADRID's customer portal "ZONA EXPO" for to manage participation.
- Exhibitor passes according to the contract (see point 2.3)
- Online invitations according to the contract (see point 2.3)
- Discount vouchers for transport.
- Premium wifi connection for 3 users during the entire fair (these connections will only work with devices that allow connection in the 5 GHz band). The password is enabled for the duration of the fair and until the last day of dismantling and is sent by mail to the holder's address at least 48 hours in advance.
- **Functionalities of connection with other users to generate business opportunities (on the digital platform):**
 - Search for new contacts among registered visitors and exhibitors
 - Communication with contacts (chat and videoconference)
 - Organization of personal online and face-to-face meetings with contacts
 - Preparation of company meetings at the stand at the fair to optimize time
 - Scanning of visitor passes at the fair
 - Downloading of the list of contacts with their details

What will you find on the GLOBAL MOBILITY CALL digital platform?

The digital platform is the digital ecosystem **that fosters connections with other professionals**, facilitates the preparation of meetings, offers exclusive content and activities and generates business opportunities.

Business and networking

Identify leads to generate business and schedule high-value meetings.

Post-fair ecosystem

Activity and visibility after the show: access and share content, participate in challenges and much more.

Positioning

Highlight your company and increase the visibility of your offer.

What can I do from my Exhibitor area on the GLOBAL MOBILITY CALL digital platform?

- Update my company details visible in the web catalogue and on the GLOBAL MOBILITY CALL
- the GLOBAL MOBILITY CALL digital platform.
- Add my products and services, which will be visible on the GLOBAL MOBILITY CALL digital platform.
- Register users from my team to access the digital event on the GLOBAL MOBILITY CALL digital platform.
- Manage the exhibiting company's agenda and company meetings at my stand at the trade fair.

What can I do on the GLOBAL MOBILITY CALL digital platform?

- Search for interesting contacts in the professional network
- Request and accept to be a contact for chatting and video conferences
- Request and/or accept appointments for professional meetings at my stand at the fair or by videoconference.
- Complete my professional profile as a user of the platform and my personal availability agenda for meetings.
- View information on what other exhibitors have to offer.
- Consult the activities and conferences both on-site and online and note them in my diary.
- Scan visitor badges at the fair.
- Download my contact list

1. HOW TO PARTICIPATE. REGULATIONS

1.6 Your Space at the Fair. Stand Types. Regulations and assembly

TYPES OF STAND

Exhibition areas and types of assembly for each area.

- **Floor + premium modular stand:** Modular stand, aluminum structure with white canvas wall covering. The stand will be open on one or more sides/aisles depending on the location.
- **Free design booth:** Floor only. Space contracting only to build your own stand whose assembly project must be approved by IFEMA MADRID.
- **Floor + Starts up modular stand:** Melamine wall structure. The stand will be open on one or more sides/aisles depending on the location.

Participating in the fair requires contracting the following general services:

- ❖ Liability insurance (coverage up to €60,000)(*)
- ❖ Multifair insurance (coverage up to €50,000)(*)
- ❖ Minimum energy consumption (0.13 kW/m²)(*)
- ❖ Assembly rights (service included with the Basic Turnkey Stand Basic Stand)(*)
 - **Type A:** Undecorated spaces, or spaces covered with carpet or platform.
 - **Type B:** Basic aluminum modular stands or similar.
 - **Type C:** Custom-designed modular stands, carpentry stands, and other materials.

❖ Exhibitor Conecta Plan.

(*) Services already included with the Basic Turnkey Stand.

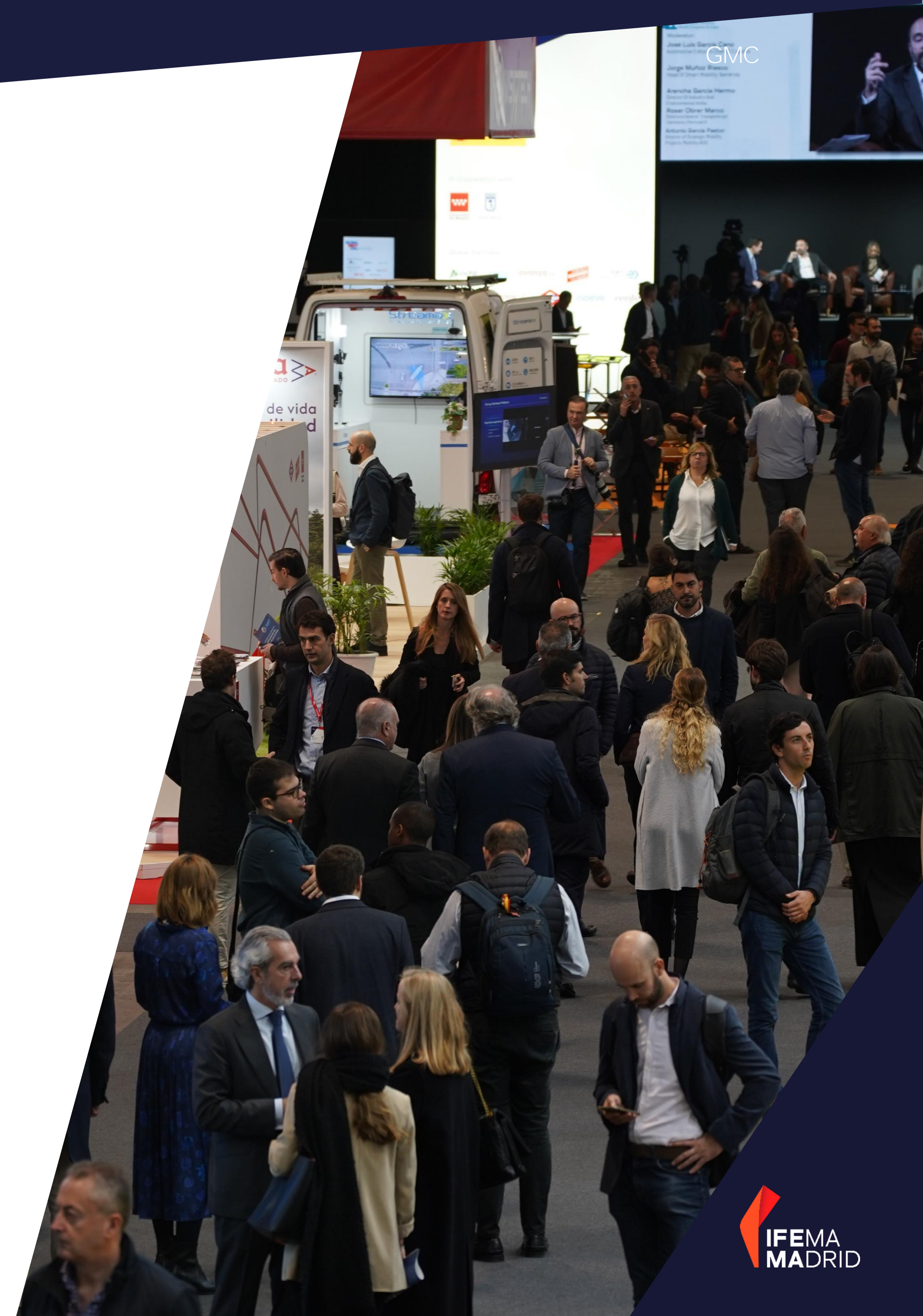

1. HOW TO PARTICIPATE. REGULATIONS

TYPES OF STAND

FLOOR + MODULAR STAND



STAND

The minimum area required to sign a contract is 9 s.q.m

- ✓ Booth open to one or several aisles
- ✓ Structure: aluminum frames 2.5m. high with white canvas walls.
- ✓ Signage: standardized lettering with the exhibitor's name.

Premium Customization

Our Premium stand is fully tailored to your brand's image, with options in colors, finishes, and exclusive graphics. Design a unique space that stands out at the fair. Customize your modular stand with our Stand Graphic Decoration service at standspremium@ifema.es

WAREHOUSE with door in the following proportion:

- From 9 to 15,5 sqm.....without warehouse
- From 16 to 23,5 sqm.....1x1
- From 24 to 31.5 m².....2x1
- From 32,5 m².....3x1

FAIR-TYPE CARPET

In jasper grey color, other colors available at Zona Expo. The exhibitor must indicate the chosen carpet color before **May 20, 2026**. If no color is indicated, the default color will be jasper gray.



ELECTRICAL INSTALLATION

- LED spotlights on track at the rate of one spotlight every 4 m2 of stand that will be distributed throughout the perimeter. If you want to hire extra lighting and/or a reticulated roof, you can do so at through Ecommerce.
- Electrical panel with differential, circuit breaker and a built-in 500W socket base, Prepared for a power of 130 W/m2.
- If you need a certain distribution of the focuses, indicate this on the map that you need to upload in your Expo Zone along with the rest of the needs: warehouse location, colors, etc.

SIGNAGE

Signage in standardized lettering with name of exhibitor editable in EXPO ZONE and booth number.

Maximum 20 characters.

If the exhibitor's name field in the EXPO ZONE is not filled in, it will be labeled with the Fair Name of the Participation Application. The exhibitor must indicate the company name chosen for the sign before **May 27, 2026**.

FURNITURE:

- From 9 to 16m²: 1 table (Dom white), 4 chairs (Madrid white) and 1 wastebasket (Duero white)
- From 16.5 to 50m²: 2 tables, 6 Madrid chairs and 1 Duero wastebasket
- From 50,5 to 100m²: 2 tables (Dom white), 8 chairs, 1 white Tana counter, 1 Pisa stool and 1 Duero wastebasket.
- From 100m² and up: 2 tables (white Dom), 8 chairs, 1 white Tana counter, 1 Pisa stool and 1 Duero wastebasket.



MANDATORY AND ADDITIONAL SERVICES

In addition to the booth, this fair requires contracting: multi-fair insurance, civil liability insurance, and electricity (not included in the package). The Conecta Plan includes digital promotion, official advertising, and personalized tools.

SERVICES INCLUDED

Cleaning of the stand once a day (Type A). First cleaning with removal of the plastic covering the carpet and the daily cleaning of the soil and collection of the contents of the litter bins. Does not include the Cleaning of exposed objects.

ASSEMBLY PLAN

You can view your assembly plan in the EXPO ZONE, with the services included. In addition, you can track the state of the plan and make observations on it, in the if any changes are needed.

ORIENTATIVE DRAWING: No drilling, nailing or gluing is allowed. It shall be adapted to the dimensions of the allotted space.

REMARKS: • All services or modifications to be introduced from these characteristics shall be at the exhibitor's expense. • The elimination or substitution, by the exhibitor, of any formative element of the modular stand does not imply a reduction of the cost. • The distribution of all the elements that make up the stand, the extras requested, as well as the structural elements necessary for the support of the stand, will be adapted to the needs of the exhibitor, as long as it is technically feasible and the plan with the pertinent indications is received fifteen days before the first day of the beginning of the assembly. Once the stand has been assembled, any changes in the location of all the elements that have not been communicated on the established date will be invoiced. • All the material used, both structural and electrical, is rented and any deterioration will be invoiced according to current rates. • In addition, any exhibitor may hire elements listed in the IFEMA Services Catalogue.

1. HOW TO PARTICIPATE. REGULATIONS

TYPES OF STAND FLOOR + MODULAR STAND START-UPS

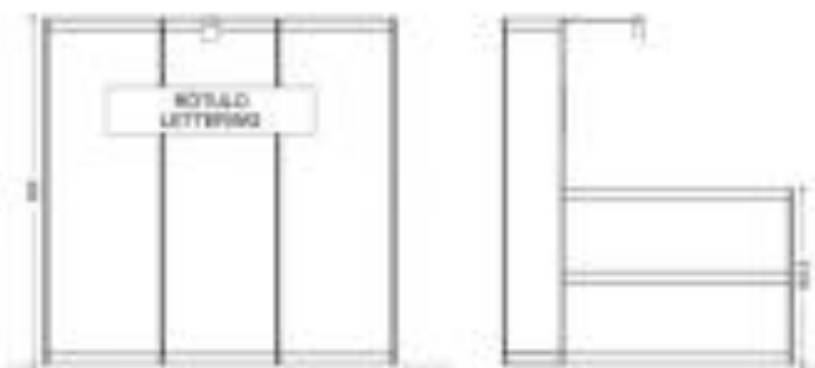

STAND

Stand open to one or several aisles depending on location.
Aluminum structure in gray color and melamine back wall.
Stand of 6 m².

FAIR TYPE CARPET

5 colors to choose in EXPO ZONE.

The exhibitor must indicate the chosen color of carpet before **May 20, 2026**
In case of not indicating the color, jasper gray will be used by default.



ELECTRICAL ENERGY AND LIGHTING

- Lighting by means of LED spotlights on rails at a rate of 1 spotlight every 3m² of stand.
- Electrical panel with magneto-thermal differential with a built-in 500W socket, prepared for a power of 130W/m².

SIGNAGE

Signage in standardized lettering with exhibitor's name editable in EXPO ZONE and booth number. **Maximum 20 characters.**
If the exhibitor's name field is not completed in the EXPO ZONE, it will be labeled with the Fair Name of the Participation Application.
The exhibitor must indicate the company name chosen for the sign before **May 27, 2026**.

SERVICES INCLUDED

- Cleaning Type A (First cleaning with removal of the plastic covering the carpet and a daily cleaning of the floor and collection of the contents of the garbage cans, once a day. Does not include the cleaning of the exhibits)
- Assembly fees included in the price.
- Multi-fair and civil liability insurance included in the price.
- Minimum electricity consumption (0.13 Kw /m²).
- EXHIBITOR PLAN CONECTA (former Marketing and Communication pack): €541 + VAT (1)

ASSEMBLY PLAN

Your assembly plan can be viewed in the EXPO ZONE with the location of the warehouse and other services included. In addition, you can track the status of the plan and make comments on it, in case you need any changes.

ADDITIONAL SERVICES

- Global Mobility Call 2025 offers a graphic design service for booth decoration (from initial definition to installation). Customize your modular stand with our Stand **Graphic Decoration service - decoraciongrafica@ifema.es**
- You can hire services and furniture from the IFEMA MADRID Services Catalogue, or find more information at ZONA EXPO.

FURNITURE (*)

- 1 white Tana counter,
 - 1 Pisa stool
- (*) furniture described or similar.



ORIENTATIVE DRAWING: Drilling and nailing is not permitted. It is permitted to stick with tape, the removal of which does not damage the panels. It shall be adapted to the dimensions of the space allocated.

REMARKS: • All services or modifications to be introduced from these characteristics shall be at the exhibitor's expense. • The elimination or substitution, by the exhibitor, of any formative element of the modular stand does not imply a reduction of the cost. • The distribution of all the elements that make up the stand, the extras requested, as well as the structural elements necessary for the support of the stand, will be adapted to the needs of the exhibitor, as long as it is technically feasible and the plan with the pertinent indications is received fifteen days before the first day of the beginning of the assembly. Once the stand has been assembled, any change in the location of all the elements that have not been communicated on the established date will be invoiced. • All the material used, both structural and electrical, is rented and any deterioration will be invoiced according to current rates. • In addition, any exhibitor may hire elements listed in the IFEMA Services Catalogue.

REGULATIONS AND ASSEMBLY OF YOUR SPACE

Installation of recyclable carpeting in common areas: in line with IFEMA MADRID's commitment to the 2030 SDGs (United Nations Sustainable Development Goals), as indicated in the [Guide for Sustainable Participation in Fairs and Events](#), and with the aim of optimizing the process of installation and removal of recyclable carpeting for subsequent reuse and consequent elimination of the protective plastic at source, the times of entry and exit of goods must be adapted to these processes and will be reflected in the corresponding point. Thank you for your collaboration with our environmental commitment, and with the aim of optimizing the process of installation and removal of recyclable carpet for later reuse and consequent disposal of the protective plastic at source, the schedules of entry and exit of goods must be adapted to these processes and will be reflected in the corresponding point. Thank you for your collaboration with our environmental commitment.

IFEMA MADRID carpets the aisles throughout the fair and, for reasons of sustainability, does so with reusable strips of standard sizes and, as a consequence, leaving a small strip of carpet free on the edges of the aisle/s bordering the stands. These non-carpeted strips **are part of the aisle and not part of the stands and therefore the exhibitor is not authorised to cover or decorate them.** We request the exhibitor's cooperation in respecting this decision; IFEMA MADRID staff will monitor compliance as far as possible, and will demand the removal of any carpeting that invades these strips and, if, despite the controls, the strip is invaded, **the invaded aisle space will be invoiced to the exhibitor as space.**

Turnkey stands. Regulations and customization.

All modular stands that include interior decoration with panels, profiles, totems, platforms, trusses, etc., must **UPDATE their project in THEIR EXPO ZONE before May 18, 2026.**

The elimination or substitution, by the exhibitor, of any element of the modular stand does not imply a reduction in cost. All the material used, both structural and electrical, is rented and any deterioration will be invoiced according to the current rates.

The distribution of all the elements that make up the stand, the extras requested, as well as the structural elements necessary for the support of the stand, will be adapted to the needs of the exhibitor, as long as it is technically feasible and the plan with the pertinent indications IS UPLOADED IN THE EXPO ZONE 15 days before the beginning of the assembly: May 20, 2026.

CUSTOMIZE YOUR STAND WITH US: DECORATION GRAPHICS FOR STANDS

Customize your modular stand with the image of your brand, to generate maximum impact on visitors. We offer a wide range of graphic materials (vinyl, foam, Forex, canvas ...) versatile and adaptable to all elements of your stand (walls, furniture, fronts, banners, displays ...).

Ask for more information and quotation. Our specialized team will follow up the production and installation.

decoraciongrafica@ifema.es for startup stands and standspremium@ifema.es for modular stands

Once the stand has been assembled, any changes in the location of all the elements that have not been communicated on the established date will be invoiced.

To contract services, you must do it through our online channel, which you can access from the following link:

[Commerce.](#)

Free design stands. Regulations and assembly

Companies opting for the free construction of their booths **must SUBMIT THEIR EXPO ZONE** the project for approval, **before May 4, 2026.**

If your project has a rigging structure, you must send rigging@ifema.es a specific project before May 4, 2026.

Assembly fees

The company in charge of the stand assembly work must pay IFEMA MADRID, before starting said work, the assembly fees corresponding to the services rendered during the Fair's assembly and dismantling period. In the event that, as the exhibitor, you wish to assume the payment of these assembly fees and have them included in your invoice, you must contract them at the Expo Zone.

In order to be more efficient and provide a better service, avoiding incidents in the assemblies, IFEMA MADRID has begun to apply a **last minute surcharge to the hiring of assembly rights, as happens with the rest of our services.**

This surcharge increases the price by 25% when the contracting is made during the week prior (7 days before) to the start of the assembly, during the assembly, celebration and disassembly.

We remind you that the assembly fees apply to free design assemblies and that they can be contracted with a 5% discount if the contracting is made up to 30 days before the beginning of the assembly of the fair.

Segunda planta.
Máxima ocupación segunda planta.

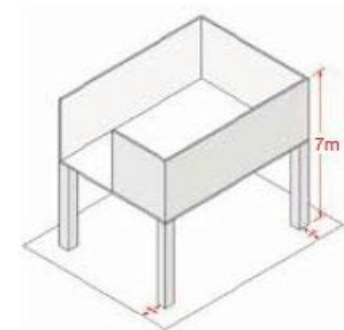

Normativa de alturas.
Máxima ocupación espacial a ocupar con cualquier elemento.

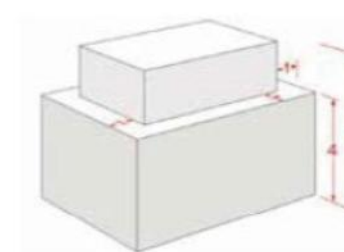

Cerramientos.

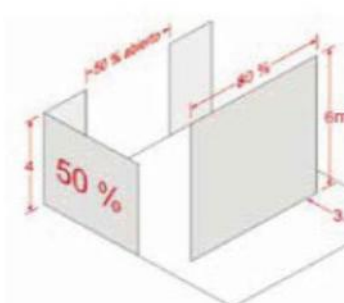

SPECIFIC INSTALLATION STANDARDS FOR FREE DESIGN STANDS

Height

- Maximum height authorized on the perimeter line: 4 m.
- To be able to raise or hang any decorative element to a maximum height of 6 m, it is necessary to set back 1 m inward around the entire perimeter.
- This possibility does not exist in the connection cores between pavilions.
- The construction, decoration, and spotlight elements must not extend more than 50 cm from the allocated space and must be at a minimum height of 2.5 m.

Blind enclosures in the perimeter environment

- The blind perimeter enclosures must not exceed 50% of each facade facing the corridor.
- To make enclosures of greater length, they must be set back at least 3 m inward and cannot exceed 80% of the length of the facade.

Second floor

- The permitted height for two-story stands is, in pavilions, 7 m.
- The second floor must be set back 1m around the entire perimeter of the stand.
- In the connection cores between pavilions and in the lateral areas of entry to pavilions 9 and 10, it is not permitted to build a second floor.
- They must present a certificate specifying the dimensions, the load capacity, and the occupancy limit, with the exhibitor being solely responsible for complying with the limits established therein.

The interpretation and application of the regulations for each particular case is the responsibility of IFEMA MADRID, which reserves the right to arbitrate exceptions if deemed necessary, based on respect for the general perspective of the fair and the visibility of neighboring stands.

DESING YOUR STAND WITH US

In addition to turnkey stands, we offer a comprehensive stand design service tailored to your specific needs, with our full guarantee. We handle everything—from space planning and design to assembly and dismantling. Request a customized project free of charge and without obligation by emailing standbuilding@ifema.es

I want to know more

[Design Stands | GLOBAL MOBILITY CALL](#)

To hire services, you must go through our online channel, which you can access via the following link: [Commerce](#).

1.7 Participation fees

TYPE OF SPACE	RATE
Floor space only: from 9,00 to 16,00 m ²	€178 /m ² + VAT(1)
Floor space only: from 16.50 to 50 m ²	€167,00/m ² + VAT(1)
Floor space only: from 50,50 to 100 m ²	€158,00/m ² + VAT(1)
Floor space only: from 100,50 m ² upwards	€150,00/m ² + VAT(1)

GMC PARTNERSHIPS	FEE
GLOBAL PARTNER	€78.000 + VAT(1)
STRATEGIC PARTNER	€63.000 + VAT(1)
CONNECTED PARTNER WITH STAND	€40.000 + VAT (1) with modular stand
CONNECTED PARTNER WITHOUT STAND	€33.000 + VAT (1) includes floor only

MANDATORY SERVICES	RATE
Civil liability insurance (covers up to €60,000)	€72,84 + VAT(1)
Multi-fair insurance (covers up to €50,000)	€69,15 + VAT(1)
Minimum electricity consumption (0.13 kW/m ²)	€7,65+ VAT(1)
Assembly Fees	
Type A: undecorated spaces or covered with carpet or platform	€2,77/m ² + VAT(1)
Type B: basic modular stands in aluminum or similar	€5,56/m ² + VAT(1)
Type C: custom-designed modular stands in aluminum, carpentry, and other materials	€8,75/m ² + VAT(1)

CONECTA PLAN (formerly Marketing and Communication pack + digital platform)	€541 + VAT(1)
Additional exhibitor passes	€5,30/ud. + VAT(1)

1.8 Deadlines and payment

MADE FOR MAKING PAYMENTS

- **February 10, 2026:** 10% deadline for the payment of the first **50% of the space** hired, deducting the space reservation fee.
- **May 4, 2026:** deadline for the **payment of 100% of the contracted space and services.**

PAYMENT METHODS

You can make the payment in the following ways:

- ❖ Transfer to: IFEMA MADRID / GLOBAL MOBILITY CALL 2025

Santander: IBAN ES64 0049 2222 5115 1000 1900 SWIFT: BSCHESMM

BBVA: IBAN ES89 0182 2370 4000 1429 1351 SWIFT: BBVAESMM

Caixa Bank: IBAN ES93 2100 2220 1102 0020 2452 SWIFT: CAIXESBBXXX

Send a copy of the bank receipt to servifema@ifema.es

- ❖ Conformed check, issued in the name of IFEMA MADRID/GLOBAL MOBILITY CALL 20266.
- ❖ Credit card in a secure environment, accessible upon completing the online participation application, or later through the Expo Zone. In accordance with current regulations, cash payments or bearer checks are not accepted.

In the Expo Zone, you will find your participation account statement for the fair and the invoices, once the payments have been made. If you need an invoice to make a payment, request it by email at atencionalcliente@ifema.es

Discounts:

5% DISCOUNT ON SERVICES CONTRACTED THROUGH EXPO AREA, UP TO 30 DAYS BEFORE THE START OF ASSEMBLY. (MAY 5, 2026)

This discount will also apply to the services they contract by sending the layout of their stand to the technical secretariat. The minimum mandatory services such as exterior advertising, meeting rooms, stand graphic decoration, and specific fair services like exhibitor passes, invitations, etc., are not included.

Surcharges:

25% increase for the hiring of services, including assembly rights, requested 7 days before the start of the assembly (May 28, 2026).

(1) Companies established in Spanish territory (excluding the Canary Islands, Ceuta, and Melilla): 10% VAT not included. For the rest of the companies, this operation is not subject to Spanish VAT. In the case of companies from the European Union, the exhibitor will be responsible for the VAT that, if applicable, is incurred in their country of establishment.

1.9 Specific Participation Rules

The decision to accept the exhibitor will be at the discretion of IFEMA Madrid, taking into account the purpose of the fair and the availability of spaces.

The minimum area for hiring is 16m².

The event management may alter the assigned spaces or make changes to the distribution of the pavilions for organizational reasons.

Without prejudice to the fact that the Fair Management will inform the exhibitors in case of relocation or significant alteration of the reserved location, each exhibitor has the obligation to inform themselves about the location of their stand, its exact dimensions, etc.

Access is not permitted to any exhibitor or visitor who cannot prove they belong to the participating professional groups, even if they have the corresponding pass or invitation.

The exhibitor is required to attend their stand and remain with the displayed products throughout the entire period and opening hours of the event. Failure to comply with this regulation could result in the loss of the right to preferential renewal of the allocated space.

The direct sale of any type of items displayed at the fair is strictly prohibited.

The exhibitor authorizes IFEMA MADRID to reproduce, in whole or in part, the products displayed in their promotional material.

The exhibitor commits to respecting the rules and guidelines for environmental protection.

Activities that may disturb other exhibitors are prohibited, and noise levels must not exceed 60 decibels.

The carrying out of promotional activities, the distribution and display of samples, brochures, flyers, and all kinds of promotional material, will be conducted solely within each exhibitor's space.

The execution of activities that require the hiring of a punctual catering service during the fair will require the completion of the "Communication for the provision of catering in stands" form available at ifema.es, which must be sent to: catering@ifema.es

The installation of WIFI access points by exhibitors is expressly prohibited, whether for connecting to the INTERNET or for presenting other functionalities. The objective of this measure is to avoid interference problems, both with the points that each Exhibitor might independently install and with the access points of IFEMA MADRID. Such interferences could cause the WIFI networks present to malfunction. For more information, you can consult Article 33 of the General Regulations for Exhibitor Participation in Fairs Organized by IFEMA MADRID.

CANCELLATION

The exhibitor's withdrawal from participation in the Fair is grounds for the termination of the contractual relationship between IFEMA MADRID and the Exhibitor for all purposes. The resignation must be communicated to the Event Management in writing addressed to them and will result in the loss of the amounts that the exhibitor should have paid by the date of communication, in accordance with the payment schedule reflected in the Participation Application.

If the resignation had been communicated to the Event Management within thirty days prior to the event's inauguration, IFEMA MADRID may require the full payment of the contracted space.

In relation to the additional services offered by IFEMA MADRID that the exhibitor had contracted prior to the communication of the resignation, the cancellation charges established in Article 7 of the general admission and contracting conditions for fairs organized by IFEMA MADRID will apply.

In the event of the fair being canceled due to force majeure, the amounts paid for concepts related to in-person participation will be refunded, according to Article 15 of **the General Participation Rules** for events organized by IFEMA MADRID.

These Specific Regulations, including the participation and assembly regulations in this chapter, are complemented by the **General Regulations for Exhibitor Participation in Exhibitions Organised by IFEMA MADRID**, which all exhibitors, by virtue of being exhibitors, accept.

1. HOW TO PARTICIPATE. REGULATIONS

1.10. Exhibitor calendar

When	What	How	Who attends to you
From February 1, 2026	Application for participation	- Continuation of the process of receiving participation applications.	Event management: globalmobilitycall@ifema.es Customer Service (Exhibitors): (+34) 91 722 30 00 atencionalcliente@ifema.es
Until February 10, 2026 Until June 4, 2026	Payments	- Until February 10, 2026: 50% of the space cost - Until June 4, 2026: 100% of the cost of the space and contracted services	Servifema: servifema@ifema.es Customer Service (Exhibitors): (+34) 91 722 30 00 atencionalcliente@ifema.es
Until May 5, 2026	Hiring of services	Hiring services with a 5% discount.	IFEMA MADRID Line Exhibitors (+34) 91 722 30 00 atencionalcliente@ifema.es
Until May 4, 2026	Free design projects	Deadline for uploading free-design projects to the EXPO ZONE. If the project has hanging elements they need be submitted in a separate project and sent to: rigging@ifema.es	Technical Secretariat IFEMA MADRID Line Exhibitors (+34) 91 722 30 00 atencionalcliente@ifema.es
Until May 20, 2026	Customisation of modular stands	-Submit projects for the interior decoration of modular stands. -Last day to choose the colour of the carpet via the Expo Zone: May 20, 2026 -Last day to complete your stand lettering in the Expo Zone: May 27, 2026 -You will have to consult the modular stand project at ZONA EXPO, or upload the same with the stipulated modifications.	Technical Secretariat Línea IFEMA MADRID Expositores (+34) 91 722 30 00 atencionalcliente@ifema.es

1. HOW TO PARTICIPATE. REGULATIONS

1.10. Exhibitor calendar

When	What	How	Who attends to you
From May 28, 2026	Booking services	25% increase on prices for last minute contracting of assembly rights and all other services.	IFEMA MADRID Line Exhibitors (+34) 91 722 30 00 atencionalcliente@ifema.es
From 4 to 6 June, 2026	Stands set-up	- June 4 and 5 from 8:30 AM to 9:30 PM. - June 6 from 8:30 AM to 7:30 PM.	-
June 7 and 8, 2026	Delivery of modular stands	- June 8 from 8:30 a.m.	Hall manager
	Incoming merchandise	- June 7 and 8: from 8:30 AM to 9:30 PM. - June 8 from 7:00 PM. Only entry through the pedestrian doors will be allowed, closing the goods gates to proceed with the installation of recyclable carpet in the aisles.	Hall manager
From 9 to 11 June, 2026	Days of the trade fair	- June 9 and 10 from 9:00 AM to 6:00 PM. June 11 from 9:00 AM to 3:00 PM	-
June 11, 2026	Outgoing merchandise	From 3:30 PM to 9:30 PM. From 3:30 PM to 4:30 PM, exit will only be allowed through the pedestrian doors to proceed with the removal of recyclable carpet. From that hour onwards, the merchandise gates will be open until 9:30 PM.	Hall manager
From 12 to 13 June, 2026	Dismantling of stands	June 12: from 8:30 AM to 9:30 PM June 13: from 8:30 AM to 3:00 PM	Hall manager

2. MANAGE YOUR PARTICIPATION

2.1 Expo Zone. Manage your participation and space. Additional services contracting. E-commerce

Access our customer area Expo Zone from the website:

<https://www.ifema.es/en/global-mobility-call> to manage your company details, contacts, and everything related to your participation. You will be able to access your participation details once it is confirmed with the user account (email used to complete the application).

What can I do in Zona Expo?

- Access details of each participation, floor plans, and projects.
- Access the exhibitor's calendar.
- View documents of interest.
- Manage exhibitor passes and request visa support letters.
- Download discount vouchers: Renfe, Iberia, Iryo.
- Send invitations.
- Register co-exhibitors.
- Access orders, payments, account statements and invoices issued
- Upload free design stand projects
- Request the distribution of modular stand elements, such as coat racks or shelves, add the sign, and choose the carpet color.
- Access e-commerce for contracting services.



2. MANAGE YOUR PARTICIPATION

2.2 Exhibitor passes and invitations. Visas. Vouchers and discounts

EXHIBITOR PASSES

Exhibitor passes will be managed from the EXPO ZONE, in the section "Event Access/Exhibitor Passes".

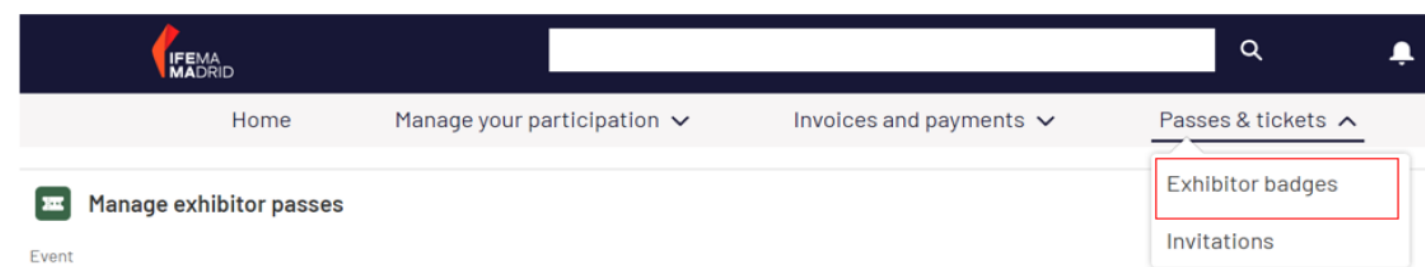

Each exhibitor will be allocated the passes that correspond to him according to his contracted surface area (from 9m² to 16m² will be allocated 4 exhibitor passes, from 16.5m² to 53.5m² will be allocated from 16.5m² to 53.5m² will have 5 exhibitor passes, from 54m² to 99.5m² will have 8 exhibitor passes, and 54m² to 99.5m² you will be entitled to 8 exhibitor passes and over 100m² you will be entitled to 10 exhibitor passes).

GLOBAL PARTNER: 10 exhibitor passes

STRATEGIC PARTNER: 10 exhibitor badges

FOCUS PARTNER: 10 exhibitor badges

In order to ensure professionalism at the fair, all exhibitor badges will be personalised: they will include the name of the badge holder, company and country. In order to prevent misuse, identity checks may be carried out at the entrances to the fair.

Exhibitors may **purchase additional exhibitor passes (€5,30/each. +VAT) through ZONA EXPO.**

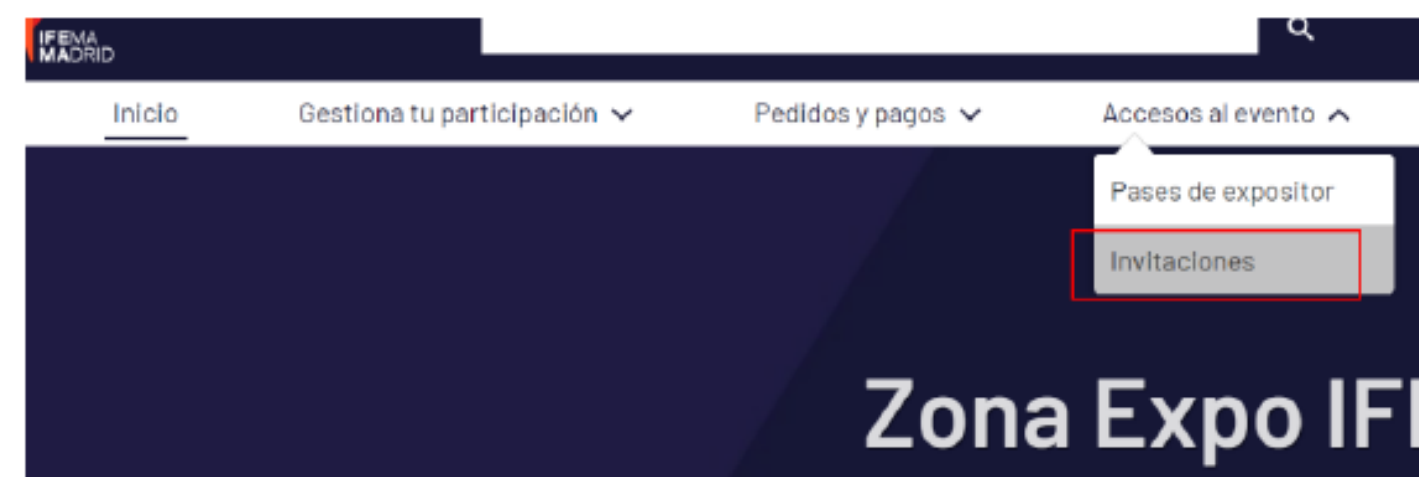
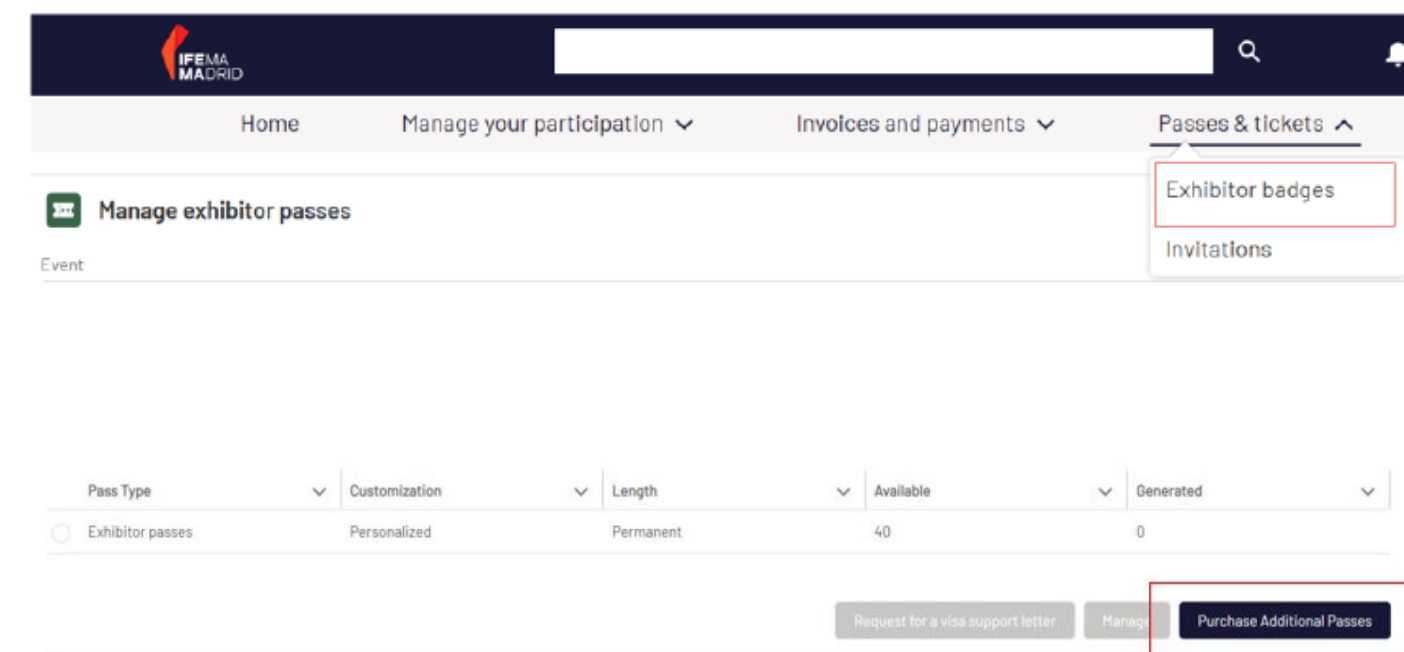

2. MANAGE YOUR PARTICIPATION

FAIR INVITATIONS (EXHIBITION): Assignment according to the contracted area and type of participation:

Each exhibitor will have professional online invitations to send to their contacts.

In case you need additional invitations, please send an email to the address: globalmobilitycall@ifema.es, indicating the exact quantity.

The online registration will be operational until October 30, 2025.

CONTRACTED AREA/TYPE OF PARTICIPATION	INVITATIONS
Stands from 9 to 16m2	150 invitations
Stands from 16,5 to 50 m2 and CONNECTED PARTNERS	400 invitations
Stands from 50m2 to 100m2 and STRATEGIC PARTNERS	600 invitations
Stands from 100m2 and above and GLOBAL PARTNERS	600 invitations

Invitations will be sent via the “EXPO ZONE/Event access/Invitations/Manage invitations”.

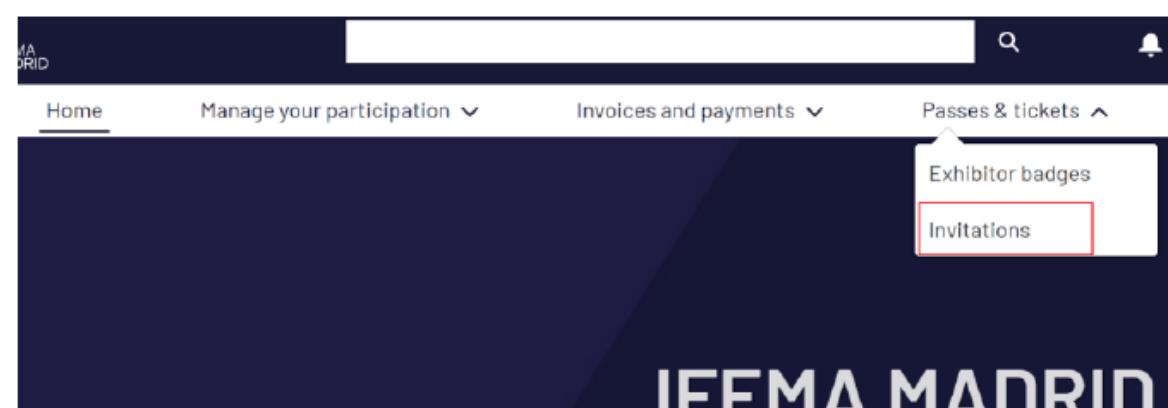

Following screen will appear for you to customise the sending:

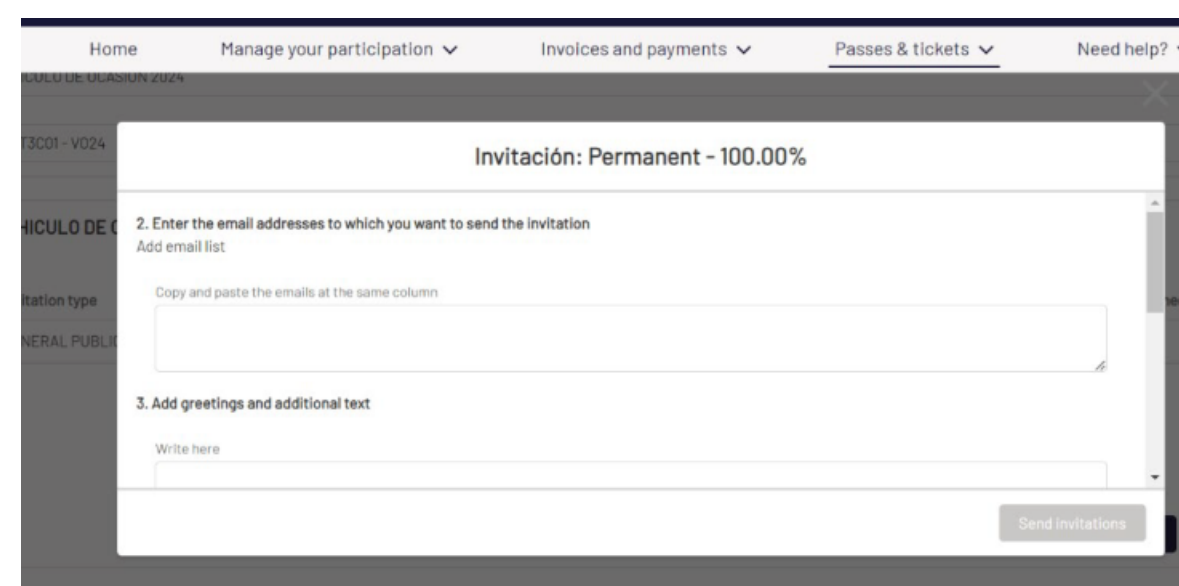

Exhibitors are urged to make good use of the invitations, sending them exclusively to professionals from the sector in order to guarantee the professionalism of the trade fair . Access controls may be carried out for this purpose.

Those who receive the **invitation code must register ONLINE through** the GMC website, ifema.es/cr in the section Purchase your pass, and entering the invitation code received to obtain their free pass to access the fair. (Invitation codes cannot be redeemed at the reception desk.

It will be strictly required for all trade visitors who are going to enter the venue with a trade visitor invitation to be accredited as trade visitors through <https://www.ifema.es/en/global-mobility-call>

VISA MANAGEMENT

If you require a travel visa, **you can request supporting letters to manage it via the EXPO ZONE.** To do so, **you must first personalise your exhibitor pass** and **have made payment** for your participation in accordance with the payment schedule (see point 1.8).

Once these two requirements have been met, via the EXPO ZONE/Event access/Exhibitor Passes section you will have access to the button Request Visa Support Letter.

We recommend start the process as soon as possible, as the deadline for visa applications is usually at least 30 days before travelling.

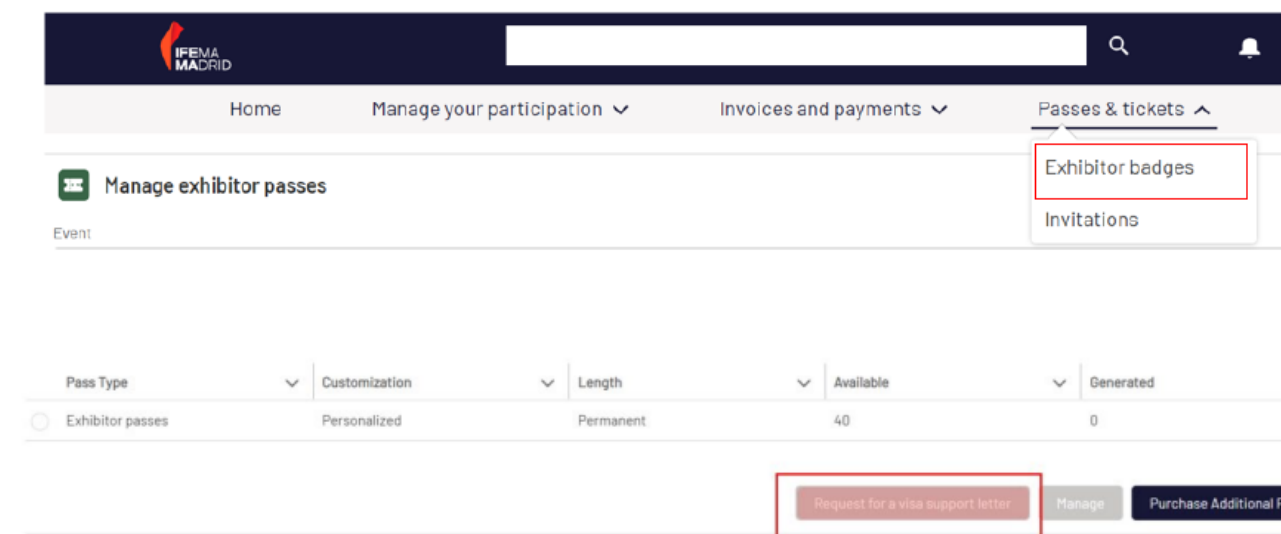

TRANSPORT DISCOUNT VOUCHERS

Once the exhibitor passes have been requested, the **corresponding transport discount vouchers can be downloaded from the EXPO ZONE** in the section Manage your participation/Documents.

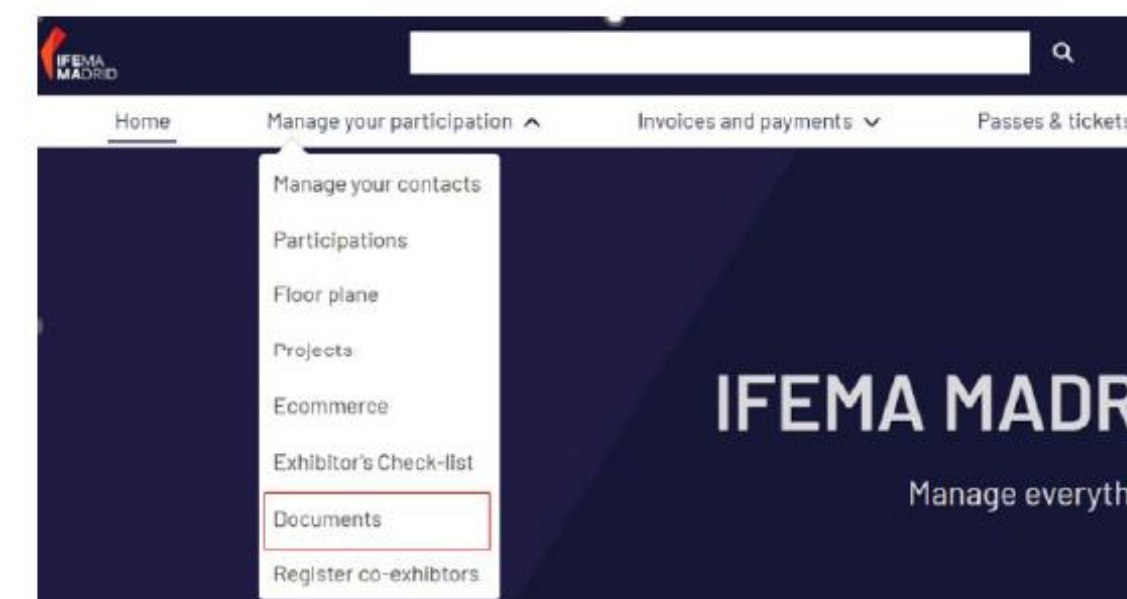

2.4 Other relevant information

DELIVERY OF MERCHANDISE TO THE TRADE FAIR CENTRE

IFEMA MADRID staff are not authorised to receive any goods intended for your booth.

In order to send goods to the site, exhibitors must specify the following on the delivery address:

- IFEMA MADRID (Avda. del Partenón, 5. 28042 Madrid. Spain)
- GMC Fair
- Name of your company.
- Hall and booth number.

The goods must be received by your company's staff at your booth and must arrive during the days designated for the entry of goods and decorative material.

If it is not possible to comply with the above, we recommend you to contact our partner company for goods management (handling and storage):

DB Schenker Office at Recinto Ferial de IFEMA MADRID: Hall 7

Tel.: +34 91 330 51 77

ifema.madrid@dbschenker.com

CUSTOM REGULATION

1. All products coming from non-EU countries must go through customs procedures, with special mention to the fact that, since 1 January 2020, the United Kingdom has been treated as a third country, so all shipments originating from the United Kingdom must regularise their merchandise through the corresponding customs procedure.

2. Exhibiting companies must have the details of the customs agent clearing their goods or, failing this, a copy of the customs documentation for entry into the European Union.

3. The material or merchandise for distribution or consumption is subject to Spanish taxes, even if they are products with no commercial value (depending on the country, the amount of taxes may vary).

4. All goods subject to a temporary regime must not be moved from the stand or leave the IFEMA MADRID trade fair centre until their situation has changed and customs formalities have been completed. It may only be deposited during these formalities in the warehouse of the official logistics agent within the trade fair centre.

5. It is strictly forbidden to sell or distribute non-Community goods at a trade fair before customs clearance has been completed.

6. Products transported as hand luggage must be declared at Barajas Airport in the RED CHANNEL ("Something to declare") and the goods must be cleared with the corresponding authority at the airport.

7. Goods that have not passed customs control and are on display will be confiscated by the customs authorities operating at the Trade Fair Centre until the appropriate documents are presented.

8. Any lorry arriving at IFEMA MADRID under a transit consigned to IFEMA MADRID, must go to the warehouse of the official Logistics Operator, for the regularisation of the transported goods, located at:

Avenida Partenón s/n

Entrada Oeste - acces on Calle Rivera del Sena

Pabellón de servicios nave 2

28042 Madrid

In order to avoid undesired incidents, and for any questions you may have, please contact our Customs Operator, DB SCHENKER: (+34) 91 330 51 77: email: ifema.madrid@dbschenker.com

CATERING AT THE BOOTH

Exhibitors who are going to offer free catering/restoration at their stand must fill out the form.

<communication for the provision of catering services at stands> Available on the IFEMA MADRID website and send it with all the requested information to catering@ifema.es

PARKING CATERING / REFRIGERATED TRUCKS

There is a parking area for catering vehicles and refrigerated trucks, with electrical connection possibilities. You can book it through the **eCommerce**

DAILY RESTOCKING OF MERCHANDISE

There is the possibility of introducing merchandise intermittently through the service doors, located at the back of the pavilions. Later, we will inform you of the patterns authorized for this purpose and the schedules for the daily restocking of goods.

ROOM RENTAL

For the event exhibitors, there is the possibility to rent rooms in the venue if you wish to prepare a workshop, reception, press conference, or product presentation during the fair. Advance reservation is required. Request a quote without any obligation via email at uanproduccion@ifema.es

[MORE INFORMATION](#)

2. MANAGE YOUR PARTICIPATION

2.5. Map



2.6. FAQ's

Question	Answer
<p>Where can I consult the IFEMA MADRID General Rules of Participation to which my participation is subject?</p>	<p>In addition to the Exhibitor's Guide, participation in GLOBAL MOBILITY CALL is subject to IFEMA MADRID's General Rules of Participation, which you should be informed about and which you can access on the IFEMA MADRID website (www.ifema.es) and via the following link IFEMA MADRID General Rules of Participation.</p>
<p>Can I hire a catering service or serve my own food and beverages at the stand?</p>	<p>Yes. Exhibitors who are going to offer a catering service at their stand (free of charge), can do so either by submitting their application with the approved catering companies at IFEMA MADRID (See the list HERE) or through other catering service providers, in which case it is essential to fill in the form "Notification for the provision of catering services on stands" available in the exhibitors' area of the institutional website and send it, with the information requested therein, to: catering@ifema.es for its information and appropriate ends.</p> <p>If IFEMA MADRID has not been notified, the Exhibitor will not be able to offer this service on their stand.</p> <p>The Exhibitor assumes responsibility for third-party complaints that are caused by said catering service, and expressly exempts IFEMA from any liability in this regard.</p>
<p>Can I extend the trade fair day by having a fun afterwork on my stand after the at my stand after the end of the fair ?</p>	<p>The celebration of a recreational afterwork outside of exhibition hours is subject to prior authorization. They can only be held on October 28 and 29, from the closing of the fair (6:00 PM) until 9:00 PM.</p> <p>It is essential to send the authorization request to globalmobilitycall@ifema.es</p>
<p>Can I access the trade fair centre with vehicles for assembly and disassembly or loading and unloading of goods?</p>	<p>Access to IFEMA MADRID and to the inside of the halls will be done through the doors and on the days and times stated in this Exhibitor's Guide. The inside of pavilions will only be accessed to unload materials. Vehicles will not be able to park inside the halls or in the adjacent areas. We would like to remind you that, for safety reasons, it is strictly forbidden to park directly in front of the goods entrance.</p> <p>IFEMA MADRID takes no responsibility for the surveillance of vehicles while they are on the grounds of Feria de Madrid.</p> <p>There is a car park for trucks and another for private cars, which can be used by paying, where appropriate, the corresponding fees. Check rates</p>
<p>Can I have a vehicle on my stand?</p>	<p>Vehicles with a combustion engine used as part of an exhibition display must have a tank filled with the minimum fuel required to access the allocated space and be able to leave it at the end of the exhibition.</p>

2.6. FAQ's

Question	Answer
Can I send goods to my booth?	<p>IFEMA MADRID staff are not authorised to receive merchandise for your stand. In order to send merchandise to the venue, the exhibitor must indicate the delivery address: IFEMA MADRID (Avda. del Partenón, 5. 28042 Madrid. Spain). GLOBAL MOBILITY CALL Trade Fair Name of your company. Hall and stand number.</p> <p>The merchandise must be received by your company's staff at your stand and arrive on the days set aside for incoming merchandise and decoration. If it is not possible to comply with the above, we recommend that you contact your freight forwarding partner: DB Schenker office at the IFEMA Trade Fair Centre MADRID: Hall 7, (+91) 330 51 77 ifema.madrid@dbschenker.com</p>
What procedure do I have to follow to hang structures in the halls/rigging?	<p>Exhibiting companies may hang elements from the ceiling of the halls following the procedure shown in the "Regulations for hanging structures in Halls" and by completing the form "Application for authorisation for hanging structures/rigging" and sending it to: rigging@ifema.es</p>
Can I hold prize draws and raffles at the stand?	<p>Raffles, prize draws, and random combination games are forms of gambling as set out in articles 3.2 and defined in article 15 of Law 6/2001 of 3 July on gambling in the Community of Madrid.</p> <p>All the information is available in the following form: https://sede.comunidad.madrid/comunicaciones-declaraciones/cifras-tombolas</p>
How do I apply for a visa support letter?	<p>Visa support letters are managed through the EXPO ZONE. To do so, you first have to personalise your exhibitor passes. Once you have managed your exhibitor passes, you can request your support letters and download them to your computer.</p> <p>It is essential to be up to date with payments according to the payment schedule in order to be able to apply for the letters.</p>
Where can I book the services for my stand?	<p>Either through the e-commerce section inside the EXPO ZONE or via the link: https://shop.ifema.es</p>
Who do I contact to book a room?	<p>Exhibitors who need to book a room should contact with: uanproduccion@ifema.es</p>

2.6. FAQ's

Question	Answer
<p>What does the CONECTA PLAN include?</p>	<p>MARKETING AND COMMUNICATION PACKAGE + Digital platform Mandatory in all modalities *..... €541 + VAT (1)</p> <p>*Included in the sponsorship packages (Global, Focus, and Strategic partners) and in the Pack for Startups (included).</p> <p>Access Digital platform for networking and innovation.</p> <ul style="list-style-type: none"> • Information Points at the celebration: located at various strategic points. Accessible to visitors, with the possibility of searching for • Exhibitors and printing of individualized location maps. • Newsletters from GLOBAL MOBILITY CALL. • SOCIAL MEDIA of GLOBAL MOBILITY CALL. • Repository News Press of GLOBAL MOBILITY CALL. • WIFI: 20MB / 5GHz band / 3 users / technical support. • Discount vouchers Renfe and Iberia. <p>In the event that the exhibitor contracts their stand after the closing date of each of the elements, making their inclusion impossible, they will also be obligated to pay €541 + VAT (1).</p>
<p>How to use the EXPO ZONE?</p>	<p>The following video shows a tutorial on the use of the EXPO ZONE</p>
<p>What are the features of my EXPO ZONE?</p>	<p><u>EXPO ZONE</u>: It is used to manage the participation of each exhibiting company at GLOBAL MOBILITY CALL</p> <ul style="list-style-type: none"> • Manage the contacts who will access the EXPO ZONE. • Access the exhibitor's calendar. • Visualise documents of interest. • Arrange exhibitor passes, request visa support letters and send invitations. • Register co-exhibitors. • Access payments, statement of accounts and invoices issued. • Upload free design stand projects. • Add signage and choose the colour of the carpeting for modular stands. • Access the e-commerce section for booking services.

2.6. FAQ's

Question	Answer
What are the benefits of my digital platform?	<p>In the exhibitor area of my company on the digital platform:</p> <ul style="list-style-type: none">• Update the company's information visible in the catalog and GLOBAL MOBILITY CALL.• Show the range of products and services.• Manage the company's appointment schedule for professional meetings at the booth.• Enrolling other team members with access to the digital Platform. <p>At the fair on the digital platform:</p> <ul style="list-style-type: none">• Complete my personal profile on the platform and my availability schedule for meetings.• Search for contacts of interest on the professional network and request and accept to be a contact for chatting and holding video conferences.• Scan professional visitor passes at the fair.• View information about the offerings of other exhibitors.• Consult the activities with the possibility of scheduling them and viewing the available digital content.
How can I request my invoices?	<p>Invoices are not generated by default. You must request them directly from the IFEMA MADRID invoicing department (atencionalexpositor@ifema.es) indicating the event at which you are exhibiting and the items to be included in the invoice. Once it has been generated, it will be available in your EXPO ZONE.</p>

2.6. FAQ's

Question	Answer
Can I decorate and/or set up my stand with IFEMA?	<p>Yes, IFEMA MADRID offers two main services:</p> <p>Graphic decoration for stands: Customise your modular stand with your brand image for maximum visitor impact. There is a wide range of versatile graphic materials adaptable to walls, furniture, front, banners... You can request information and a quote at: decoraciongrafica@ifema.es</p> <p>Stand design: this consists of a comprehensive stand design service fully adapted to your needs. From the planning of your space, design, assembly and disassembly. You can request information and a quote at: standbuilding@ifema.es</p>
Is it compulsory to attend the booth at all times?	<p>Yes, exhibitors must not leave their stand unattended and must remain with the products on display throughout the entire period and opening hours of the event.</p>
Are assembler's passes necessary during the set-up of the trade fair?	<p>No. The requirements to be allowed to enter and set up are: to have paid 100% of your participation, to have the project presented and approved, to have paid the assembly fees, and to have completed the occupational risk protocol.</p>
How can I book parking at IFEMA?	<p>Exhibiting companies will be able to book parking spaces through the e-commerce section inside the EXPO ZONE or via the link https://shop.ifema.es.</p> <p>Once the contract has been signed, parking badges can be collected from November 12 (first day of stand set-up) at the exhibitor services desk, located in the central boulevard between halls 6 and 8.</p>

2.6. FAQ's

Question	Answer
What coverage do I have as an exhibitor with the insurance included?	You can check the coverage of the compulsory insurance policies at the IFEMA MADRID exhibitor support area .
How can I access the WI-FI network as an exhibitor?	As an exhibitor you will receive as part of the CONNECT PLAN a Wi-Fi connection for 3 users during the entire trade fair for the exclusive use of stand holders. Devices that allow 5GHz network capability are required. Access codes will be sent out during the lead up to the event. Additional Wi-Fi access can be booked through the e-commerce section inside the EXPO ZONE or via the link https://shop.ifema.es
Regulations and support for exhibitors at the trade fair centre	https://www.ifema.es/en/support/exhibitors-ifema-fairgrounds
Regulations and support for fitters at the trade fair centre	https://www.ifema.es/en/support/assemblers-colaborators-fairgrounds

3. PROMOTE AND MAXIMIZE YOUR PARTICIPATION

3.1 Exhibitor catalogue

The fair's catalogue, or list of exhibiting and co-exhibiting companies, is an essential tool for promotion and networking. It provides visitors and other exhibitors with the basic information needed to prepare for the fair and helps them find and contact you before, during, and after the event.

- Enter and update your contact details, the products or services presented, and any relevant information to give your company maximum visibility and ensure you get the most return from your participation.
- All the digital environment and communication for your participation is channeled through Live Connect.
- Make the most of the platform offered by IFEMA to promote your participation, schedule appointments, showcase your products, and connect with your target audience.

3.2 Networking

Enrich your contact list.

The digital platform gives you the opportunity to search for contacts among its participants. You can use filters by country, activity, position, products of interest, etc., to conduct searches. Once potential customers are located, you can request contact (sharing data such as email and phone). Once they have accepted you, you can chat with them or invite them to an in-person meeting at the fair or a video conference at the event on the digital platform.

Be proactive and take advantage of the opportunity to build a good contact list.

Other users will be able to request meetings by directing their request either to the company in general (without prior acceptance of the contact) or to a specific team member (with prior contact). In this way, the entire team will be able to schedule their trade fair appointments well in advance.

3.3 Invitations for your clients and contacts

IFEMA provides you with access invitations to the fair to efficiently promote your participation. Don't miss out on this useful tool, which is available to you in your Expo Zone.

3.4 Outdoor and digital advertising

Advertising projects adapted to your needs

- Promote your brand before, during and after the event
- Attract new customers through the best B2B targeting in the market.

[More information here: Advertising | IFEMA MADRID](#)

See also the advertising options offered by the digital platform.

You have a wide range of promotional activities and sponsorships that will provide additional visibility and allow you to develop high-impact actions for the national and international professional public visiting the fair:

CONSULT POSSIBLE SPONSORSHIPS: globalmobilitycall@ifema.es

4. SUSTAINABILITY CULTURE MANAGEMENT AT IFEMA MADRID

GMC

At IFEMA MADRID we are not only fully committed to sustainability per se, but also to achieving the sustainable development goals (hereinafter SDGs) promoted by the United Nations, which we have incorporated into our strategic corporate management policy and culture

IFEMA MADRID's sustainability policy is mainly focused on the following SDGs: 8, 9, 11, 12, 13, 16 and 17.

IFEMA MADRID'S sustainability policy is mainly based on the following SDGs: Nos. 8, 9, 11, 12, 13, 16 and 17.

ISO Standards certified by IFEMA MADRID:

- ISO 9001: Quality Management,
- ISO 20121: Event Sustainability Management.
- ISO 14001: Environmental Management,
- ISO 50001: Energy Management,
- ISO 22320: Emergencies Management.

ACTIONS TAKEN AT IFEMA MADRID TO REDUCE GAS EMISSIONS AND BE MORE ENERGY EFFICIENT:

- 100% certified electrical energy of renewable origin.
- Geothermal installation in Puerta Sur building.
- Low consumption lighting in our halls and on our modular stands.
- Controlling the temperature of our air-conditioning / HVAC systems.

IFEMA MADRID is in possession of "calculo" (I calculate) and "reduzco" (I reduce) stamps in Carbon Footprint Scopes 1 and 2.

WASTE MANAGEMENT:

• The exhibitor/assembler is the generator of the waste and shall therefore be responsible for its removal and management. How the waste generated by the exhibitor is managed is explained in article 35 of the General Rules of Participation.

• We offer our exhibitors a service that includes the removal and management of the waste they/their assemblers generate. (check our fees in Exhibitors' Area).

Carpet recycling:

IFEMA MADRID recycles 100% of the carpeting used in aisles and communal areas. To do so it has been essential to change our assembly and disassembly process, that affects the entry and removal of goods (check the corresponding item) . Furthermore, means that it has to be laid in strips instead of covering the entire surface area as was previously the case. This means we can guarantee its conversion into a new raw material for the subsequent manufacture of other products.

SUSTAINABLE MOBILITY:

IFEMA MADRID offers access to public transport close to its facilities (metro and bus), parking for electric cars with 100% renewable electricity charge points, as well as a parking area for bicycles and scooters

GUIDE TO SUSTAINABLE PARTICIPATION IN TRADE FAIRS/EVENTS:

IFEMA MADRID has published its Guide to Sustainable Participation in Trade Fairs for exhibitors on its website. We recommend you read it before starting to prepare your participation:

ifema.es/en/about-us/quality-sustainability



5. CONTACT US

Department	Ask me about	Contact							
Commercial Department	<ul style="list-style-type: none"> Contracting space General topics of participation in the fair Exhibitor passes Trade visitor invitations Activities and forums at the Fair 	<table border="1"> <tr> <td>Director</td> <td>David Moneo</td> <td rowspan="3"> (+34) 91 722 30 00 globalmobilitycall@ifema.es </td> </tr> <tr> <td>Coordinator</td> <td>Leyre Delgado</td> </tr> <tr> <td>Commercial Area</td> <td>Borja Frutos</td> </tr> </table>	Director	David Moneo	(+34) 91 722 30 00 globalmobilitycall@ifema.es	Coordinator	Leyre Delgado	Commercial Area	Borja Frutos
		Director	David Moneo	(+34) 91 722 30 00 globalmobilitycall@ifema.es					
		Coordinator	Leyre Delgado						
Commercial Area	Borja Frutos								
IFEMA MADRID Customer Service	<ul style="list-style-type: none"> Hiring of services Expo Zone Visitor Information 	(+34) 91 722 30 00 atencionalcliente@ifema.es							
Technical Secretariat (Trade Fair Services Department)	<ul style="list-style-type: none"> Technical support to exhibitors and assemblers Review of stand assembly projects Solutions to technical problems during the exhibition activity Customization of modular stands Coordination for stand catering 	(+34) 91 722 30 00 stecnica@ifema.es catering@ifema.es							
Graphic decoration	Hiring of graphic materials to customize your booth	(+34) 91 722 30 00 decoraciongrafica@ifema.es							
Full service stand design	Design and assembly of free-design stands	(+34) 91 722 30 00 standbuilding@ifema.es							
Floor + modular stand design enquiries	Stand design and assembly: floor + modular stand	standspremium@ifema.es							
Floor design enquiries + modular stand start-ups	Stand design and assembly: floor + modular start-up stand	stecnica@ifema.es							

5. CONTACT US

Department	Ask me about	Contact
Outdoor Advertising	Hiring of advertising media at the fairgrounds	(+34)91 722 53 40/08 publicidadexterior@ifema.es
Communication and Marketing Management	Media relations	<div style="display: flex; justify-content: space-between;"> <div> <p>Director: Raúl Díez Director of Communications: Raúl Díez Press Officer: Marco Presa International Press: Elena Valera Press Secretary: Pilar Serrano</p> </div> <div> <p>(+34)91 722 50 93 mpresa@ifema.es</p> </div> </div>
Planning and Control Management	<ul style="list-style-type: none"> Rental of the different meeting and convention spaces at the fairgrounds, both during and outside the fairs. Coordination of extra-fair activities 	(+34)91 722 30 00 uanproduccion@ifema.es
Institutional Relations (Protocol)	<ul style="list-style-type: none"> Institutional visits Guided tours Protocol for all Events Institutional relations 	(+34)91 722 30 00 infoifema@ifema.es
Safety and Self-Protection Management	<ul style="list-style-type: none"> General security and parking Access to the Fairgrounds 	(+34)91 722 50 65 dseguridad@ifema.es
Medical Service and Security Emergencies	<ul style="list-style-type: none"> Medical emergency Health care for exhibitors and visitors during the celebration of fairs, set-up and dismantling. 	(+34)91 722 54 00

Thank you

