

EXPODENTAL

International Dental Equipment, Supplies
and Services Show

Exhibitor's Guide
and Specific Rules
of Participation

11-13
Mar
2026

ifema.es

In collaboration with:



Sponsor:



INDEX

1. HOW TO PARTICIPATE

- 1.1 Dates, schedule, and venue. Invited sectors
- 1.2 What do I need to do to participate?
- 1.3 Space allocation and contracting
- 1.4 Participation options
- 1.5 Digital Platform: the digital platform accessible with your exhibitor plan
- 1.6 Stand types
- 1.7 Participation fees
- 1.8 Deadlines and payment methods
- 1.9 Specific fair regulations
- 1.10 Exhibitor calendar

2. MANAGE YOUR PARTICIPATION

- 2.1 EXPO ZONE. Manage your participation and space. Additional services contracting. E-commerce
- 2.2 Registration of co-exhibitors
- 2.3 Exhibitor passes and invitations. Visas. Vouchers and discounts
- 2.4 Other relevant information
- 2.5 Map
- 2.6 FAQs

3. PROMOTE AND MAXIMIZE YOUR PARTICIPATION

- 3.1 Exhibitor Catalogue
- 3.2 Speaker´s Corners.
- 3.3 Networking
- 3.4 Outdoor advertising

4. SUSTAINABILITY MANAGEMENT AT IFEMA MADRID

5. CONTACT US

1.1 Dates, Schedule, and Venue.

EXPODENTAL will take place at the **IFEMA MADRID exhibition centre from 11 to 13 of March 2026** from **10.00 a.m. to 8.00 p.m.** Exhibitors will be able to access the site from 9.00 a.m. and leave it before **9.00 p.m.**

The virtual event via the Digital Platform platform will be open from **15 January to 11 June 2026.**

The character of the fair is 'professional'.

The occupied halls will be: 4,6 y 8.

In order to apply to participate in the fair, it is a requirement that the activity of the company, public or private organisation, must fall within the sectors covered by the fair:.. sectors covered by the fair:.. Implantology, Orthodontics, Consumption and instrumentation of prosthesis equipment and furniture, training and management.

1.2 What do I have to do to participate?

The application to participate begins by completing, within the established deadline, the online Application to Participate form available on the fair's [website](#).

The submission of the Application to Participate implies full acceptance of the **General Rules of Participation in Exhibitions organised by IFEMA MADRID**, the technical annexes, the Specific Rules of this edition and any generic or specific provisions established by the fair organisers.

The exhibitor company is the company in whose name the application to participate as an exhibitor is completed.

By clicking on the send application button, the exhibitor confirms to IFEMA MADRID that he/she is seriously interested in participating as an exhibitor and in receiving a proposal.

The decision to accept the exhibitor shall be at the discretion of IFEMA MADRID, taking into account the purpose of the fair and the availability of space.

IFEMA MADRID will make one or more space/location proposals depending on the type of participation and/or type and size of stand requested. This proposal constitutes a contracting offer. If the contracting party accepts the offer/quote in writing/email/signature or during a meeting to choose spaces, the contract for participation in the fair will be formalised.

1.3 Contracting and allocation of space.

FIRST ALLOCATION

To exhibiting companies that submit the Participation Application Form together with payment of the space reservation fee together with the payment of the space reservation fee, **before 15 September 2025**, they will be called to the space selection meeting, scheduled for 23, 24 and 25 September.

The criteria applied to define the order of election will be as follows following:

- Surface area: the one with the largest surface area requested will be chosen first, organised by sections.
- Uninterrupted participation in the fair.
- In equal conditions of the previous criteria, the order of choice will be made order of choice will be made by drawing lots at that time.

Contracting and awarding of spaces:

All applications forms received from companies after **September 15, 2025** will be processed, once the choice of spaces has been finalised, in strict order of receipt and subject to space availability.

SPACE CONFIRMATION

Once a proposal of location and surface area has been accepted, the Application for participation constitutes a non-revocable commitment by the applicant.

Once the final details of the application have been agreed upon, the exhibitor will receive from the Show Management the corresponding Exhibition Contract with the statement of accounts the corresponding Exhibition Contract with the statement of accounts, location plan and dimensions of the stand/s, as well as all the of the stand/s, as well as all the information on the services offered by IFEMA MADRID offered by IFEMA MADRID, which will allow you to make the most of your presence at the fair your presence at the fair to the maximum.

CANCELLATION

The exhibitor's cancellation of his participation in the Show shall be termination of the contractual relationship between IFEMA MADRID and the Exhibitor for all purposes. the Exhibitor for all purposes. Cancellation must be communicated to the Show Management in writing addressed to the same and will entail the loss of the amounts that the Exhibitor should have paid at the date of notification, in accordance with the date of communication, in accordance with the calendar of payment deadlines of payment reflected in the Participation Application Form.

If the Show Management has been notified of the cancellation within the thirty days prior to the date of within the thirty days prior to the opening of the event, it may be demanded by IFEMA MADRID may demand full payment of the contracted space. contracted.

In relation to the additional services offered by IFEMA MADRID which the exhibitor has contracted prior to the communication of the notice of cancellation, the cancellation charges of the established in article 7 of the general conditions of admission and contracting at events of admission and contracting at events organised by IFEMA MADRID.

In the event of cancellation of the fair due to force majeure, the amounts paid for the amounts paid for concepts related to participation in person, as per article 7 of the participation, in accordance with article 15 of the **General Rules for Participation** in events organised by IFEMA MADRID.

1. HOW TO PARTICIPATE

EXPODENTAL

1.4 Participation Options.

- **Exhibitor:** is the natural or legal person, which has space at the the fair. The exhibiting company is the company in whose name the application to participate as an exhibitor is completed. The exhibitor has the option of contracting a 'basic turnkey stand' or contracting only the space to build his own 'free design stand'.
- **Co-exhibitor:** Participating in the stand of a main exhibitor by contracting directly with them.
- **Grouped participations:** these are those organisations, institutions or associations that request the total associations that apply for the total number of square metres for the participation of their represented companies, which will be the exhibitors at the fair.

There are two types of grouped participation:

1. With companies registered as direct exhibitors and, therefore, with all the rights to a single stand.
2. With companies registered as co-exhibitors.

In this case, any participation that has not registered its companies through ZONA EXPO, companies through ZONA EXPO, and the commercial management verifies during the during the fair that they are participating in their stand, will be invoiced for their participation.

Grouped participations will only be eligible for three payment modalities payment:

1. The contracting and/or invoicing company pays for the floor space + services mandatory contracting services of all its related companies.
2. The contracting and/or invoicing company pays only for the amount of the contracted land of all related companies.
3. Each related company pays its share. There cannot be more than one invoicing company per grouped participation.



1.5. Digital Platform: the digital platform you have access to with your Exhibitor Plan.

What will you find at Digital Platform?

Digital Platform is a digital ecosystem that **fosters connections with other professionals**, facilitates meeting preparations, offers exclusive content and activities, and generates business opportunities.

- **Business and networking:** Identify leads to generate business and schedule high-value meetings.
- **Post-fair ecosystem:** Activity and visibility after the fair: access and share content, participate in challenges, and much more.
- **Positioning:** Highlight your company and increase the visibility of your offering.

What can I do from my Exhibitor Area in Digital Platform?

- Update my company details visible in the web catalogue and in EXPODENTAL Digital Platform.
- Add my products and services, which will be visible EXPODENTAL Digital Platform.
- Register team members so they can access the digital event EXPODENTAL Digital Platform.

What can I do during the digital event Expodental Digital Platform?

- Search for relevant contacts in the professional network
- Contact request for chatting and videoconference.
- Request and/or accept appointments for professional meetings at my stand at the fair or by videoconference.
- Complete my professional profile as a user of the platform and set my availability agenda of for meetings.

- Check out onsite and online activities and add them to your calendar.
- View information on what other exhibitors offer.
- Scan visitor passes at the fair.

CONECTA EXHIBITOR PLAN

Participation as an exhibitor or co-exhibitor at the fair requires contracting the **CONECTA EXHIBITOR PLAN (former Communication and Marketing Pack + Digital Platform): 395€ + VAT (1)**

This concept includes the following services:

- Dissemination of participation in the fair through inclusion in the list of exhibitors accessible in open access on the website ifema.es/en/expodental and shared as a link in sectoral communications.
- Presence as exhibitors in the digital event of the **Expodental Digital Platform**. The digital event extends the duration of the fair beyond the event itself, provides additional content on the exhibition and sector news and is accessible to exhibitors and registered visitors.
- Presence during the fair on floor plans and exhibitor lists.
- Access to **IFEMA MADRID "EXPO ZONE"** customer private area for managing participation.
- Exhibitor passes according to the contracted space (see point 2.3).
- Online invitations according to the contracted space (see point 2.3).
- Discount transport vouchers.
- Premium Wi-Fi connection for 3 users throughout the fair (these connections only work with devices compatible with the 5 GHz band). The password will be activated for the fair's duration and will be sent to the registered email address at least 48 hours before the event

Functionalities for connecting with other users to generate business and networking opportunities:

- Search for new contacts among registered visitors and exhibitors.
- Communication with contacts (chat and videoconferencing).
- Preparation of meetings to optimise time at the trade fair.
- Scanning of visitor passes at trade fairs.

(1) Companies based in Spain (excluding the Canary Islands, Ceuta and Melilla): 10% VAT not included. For other companies this operation is not subject to Spanish VAT. For companies based in the European Union, the exhibitor shall be liable to VAT and may, if applicable, claim it back in the country where the company is domiciled.

1. HOW TO PARTICIPATE

EXPODENTAL

1.6 Stand Types

- **Basic Turnkey Stand:**

NEW

Aluminium beater structure and white recycled panel walls covering the structures.

- **Floor Space Only:**

Only floor space. This option involves renting space only, and exhibitors must submit a stand construction project for **IFEMA MADRID** approval.

Participating in the fair requires contracting the following general services:

- Liability insurance (coverage up to €60,000)(*)
- Multifair insurance (coverage up to €50,000)(*)
- Minimum energy consumption (0.13 kW/sq.m)(*)
- Assembly rights (service included with the Basic Turnkey Stand Basic Stand)(*)
 - **Type A:** Undecorated spaces, or spaces covered with carpet or platform.
 - **Type B:** Basic aluminum modular stands or similar.
 - **Type C:** Custom-designed modular stands, carpentry stands, and other materials.
- Conecta Exhibitor Plan. (Former Marketing and Communication Pack) 395€ + VAT (1)

(*) Services already included with the Modular Stand.



BASIC TURNKEY STAND NEW

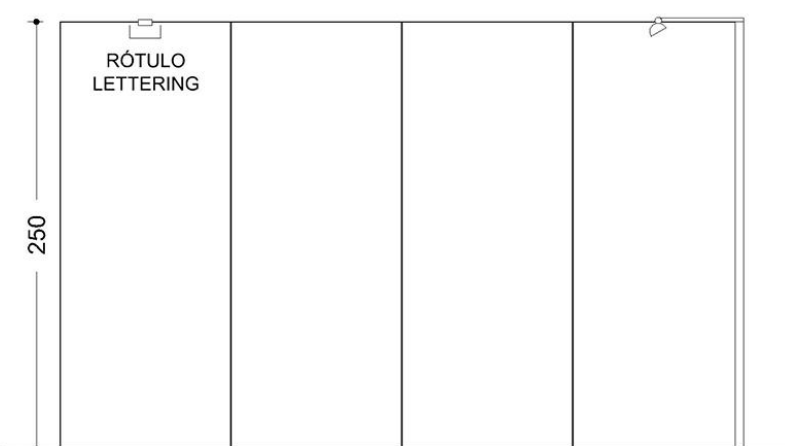

STAND

- The minimum area to hire is 16 sq.m
- Stand open to one or more aisles.
- Structure of modular aluminum frames connected internally at a height of 2.5 sq.m made with palboard material (pvc sheets) in white colour. The change of color will be invoiced as an extra complement, upon request of quotation.

WAREHOUSE with lockable door with code in the following proportion:

- For 23,5 sq.m.....1x1 sq.m
- For 24 to 31,5 sq.m2x1 sq.m
- For 32 sq.m or larger3x1 sq.m

TRADE FAIR CARPET

5 colours to choose from in the EXPO ZONE.
Exhibitors must indicate their chosen carpet colour by **17 February 2026**.
If no colour is indicated, the default colour will be jasper grey.

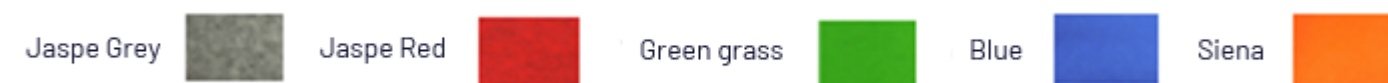

LETTERING

Standard lettering with exhibitor's name, editable in EXPO ZONE and stand number. **Maximum 20 characters.**

If the exhibitor name field is not completed in the EXPO ZONE, it will be labelled with the Trade Fair Name on the Participation Application Form. The exhibitor must indicate the company name chosen for the sign before **24 February 2026**.

ELECTRICITY AND LIGHTING:

- Electrical panel at a rate of 130wx sq.m.
- 1 led spotlight of 25w per 4 sq.m.
- Double socket base.

SERVICES INCLUDED

- Daily cleaning of the stand (Type A, once a day).
- Assembly fees included in the price.
- Multi-fair and civil liability insurance included in the price.
- Minimum electricity consumption (0.13 Kw /sq.m).
- Conecta Exhibitor Plan

CLEANING TYPE A:

First cleaning with removal of the plastic covering the carpet and daily cleaning of the floor and collection of the contents of the litter bins. Does not include the cleaning of the exhibits.

ASSEMBLY PLAN

Your assembly plan can be viewed in the EXPO ZONE with the location of the warehouse and other services included. You can also monitor the status of the plan and comment on it in case you need to make any changes.

ADDITIONAL SERVICES

Personalice su stand premium con standspremium@ifema.es

INDICATIVE DRAWING. Drilling and nailing are not permitted. Adhesive tape may be used, provided that its removal does not damage the panels. It must be adapted to the dimensions of the space allocated.

OBSERVATIONS: •Any services or modifications that may be introduced based on these characteristics shall be at the exhibitor's expense. •The elimination or substitution, by the exhibitor, of any formative element of the modular stand does not imply a reduction in the cost. • The distribution of all the elements that make up the stand, the extras requested, as well as the structural elements necessary for the support of the stand, shall be adapted to the needs of the exhibitor, provided that it is technically feasible and that the plan with the relevant indications is received fifteen days before the first day of the start of assembly. Once the stand has been assembled, any changes to the location of all the elements that have not been communicated on the established date will be invoiced. • All the material used, both structural and electrical, is for hire and any deterioration will be invoiced according to the current price list. •In addition, any exhibitor can hire elements listed in the IFEMA MADRID Services Catalogue.

MODULAR ENTERPRISE STAND

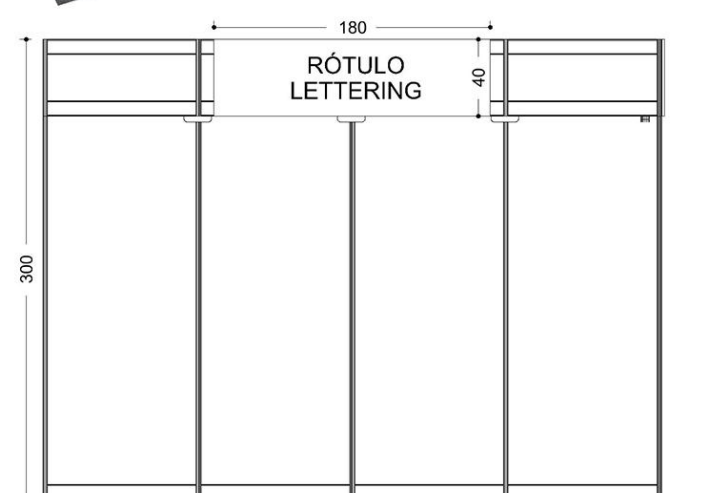

STAND

Stand open to one or several aisles depending on location.
Aluminum structure in gray color and melamine walls.

- 9 sq.m 3.624€ + VAT (1)
- Additional sq.m 334 € + VAT (1)

TRADE FAIR CARPET

The default color will be Gray.

Jaspe Grey



ELECTRICITY AND LIGHTING

- Lighting by means of LED spotlights on rail at a rate of 1 spotlight every 3 sq.m of wall.
- Electrical panel with magneto-thermal differential, prepared for a power of 130 w/sq.m, and a built-in 500w socket.

LETTERING

Standard lettering with name of exhibitor editable in EXPO ZONE and stand number. **Maximum 20 characters.**

If the exhibitor's name field is not completed in the EXPO ZONE, it will be labelled with the Trade Fair Name on the Participation Application Form. The exhibitor must indicate the company name chosen for the sign before **24 February 2026**.

SERVICES INCLUDED

- Daily cleaning of the stand (Type A, once a day).
- Assembly fees included in the price.
- Multi-fair and civil liability insurance included in the price.
- Minimum electricity consumption (0.13 Kw /sq.m).
- Conecta Exhibitor Plan

CLEANING TYPE A:

First cleaning with removal of the plastic covering the carpet and daily cleaning of the floor and collection of the contents of the litter bins. Does not include the cleaning of the exhibits.

ASSEMBLY PLAN

Your assembly plan can be viewed in the EXPO ZONE with the location of the warehouse and other services included. You can also monitor the status of the plan and comment on it in case you need to make any changes.

ADDITIONAL SERVICES

Customise your modular stand with our Stand Graphic Decoration service decoraciongrafica@ifema.es

CONDITIONS FOR RECRUITMENT

Space reserved for: schools and postgraduate centres, clinic management companies, universities, clinic architecture.

INDICATIVE DRAWING. Drilling and nailing are not permitted. Adhesive tape may be used, provided that its removal does not damage the panels. It must be adapted to the dimensions of the space allocated.

OBSERVATIONS: •Any services or modifications that may be introduced based on these characteristics shall be at the exhibitor's expense. •The elimination or substitution, by the exhibitor, of any formative element of the modular stand does not imply a reduction in the cost. • The distribution of all the elements that make up the stand, the extras requested, as well as the structural elements necessary for the support of the stand, shall be adapted to the needs of the exhibitor, provided that it is technically feasible and that the plan with the relevant indications is received fifteen days before the first day of the start of assembly. Once the stand has been assembled, any changes to the location of all the elements that have not been communicated on the established date will be invoiced. • All the material used, both structural and electrical, is for hire and any deterioration will be invoiced according to the current price list. •In addition, any exhibitor can hire elements listed in the IFEMA MADRID Services Catalogue.

1. HOW TO PARTICIPATE

EXPO DENTAL

1.7 Specific rules of participation

MODULAR STANDS

The distribution of all the elements that make up the stand, the requested extras, as well as the structural elements necessary for the support of the stand, will be adapted to the exhibitor's needs, as long as it is technically feasible and the plan with the pertinent indications IS UPLOADED IN THE EXPO ZONE one month before the beginning of the assembly: **February 4, 2026.**

The elimination or substitution, by the exhibitor, of any element of the modular stand does not imply a reduction in cost. All the material used, both structural and electrical, is rented and any deterioration will be invoiced according to the current rates.

Once the stand has been assembled, any changes in the location of all the elements that have not been communicated on the established date will be invoiced.

CUSTOMIZE YOUR STAND WITH US: GRAPHIC DECORATION FOR STANDS/ADDITIONAL SERVICES

Customize your modular booth with your brand image to generate maximum impact on visitors. We offer you a wide range of graphic materials (vinyl, foam, Forex, tarpaulins...) versatile and adaptable to all the elements of your stand (walls, furniture, fronts, banners, displays...). Ask for more information and quotation.

Our specialized team will follow up the production and installation
decoraciongrafica@ifema.es



FREE DESIGN STAND

Second Floor

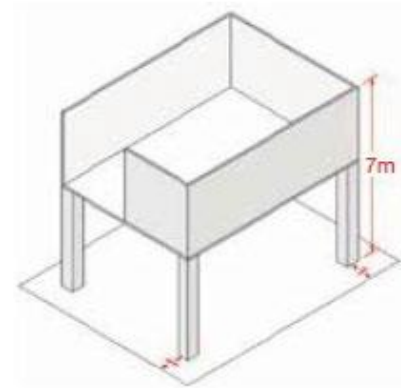

Height Standard

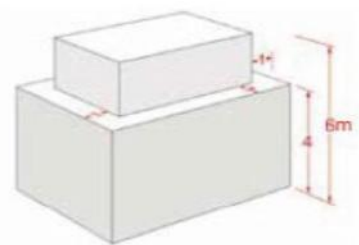

Enclosure

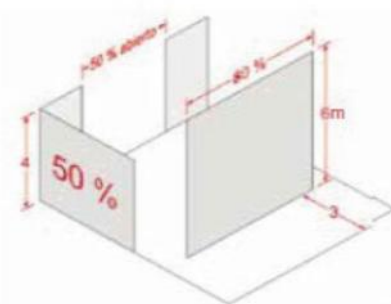

SPECIFIC ASSEMBLY RULES FOR FREE-DESIGN STANDS

The minimum contract area is 16 sq.m.

Height

- Maximum authorised height within the perimeter line. 4 sq.m
- In order to raise or hang any decorative element to a maximum height of 6 sq.m, a 1 sq.m margin must be left within the inside of the perimeter of the whole stand.
- This possibility does not exist in the connecting nuclei between halls, nor on the entrance sides of Halls 9 and 10.
- Building elements, decoration and spotlights may not protrude more than 50 cm from the allotted space and from a minimum height of 2.5 sq.m.

Blind perimeter walls in the perimeter environment

- Blind perimeter walls cannot make up more than 50% of each side facing an aisle.
- Longer walls must be set back at least 3 m from the perimeter and cannot make up more than 80% of the length of the façade.

Second Floor

- The maximum permitted height for two-storey stands is 7 sq.m in the halls.
- The second floor must be set back 1 m within the entire perimeter of the stand.
- It is not permitted to build a second floor in the connecting nuclei between the halls and in the side entrance areas to Halls 9 and 10.
- They must present a certificate specifying the dimensions, the load of use and the seating capacity, it being the sole responsibility of the exhibitor to comply with the limits established therein.

The interpretation and application of the regulations for each individual case is the responsibility of IFEMA MADRID, which reserves the right to arbitrate on exceptions, if it deems necessary, on the basis of respect for the general appearance of the Fair and the visibility of neighbouring stands.

Companies opting for the free construction of their stands must SUBMIT THEIR EXPO ZONE the project for approval **before February 11, 2026.**

If your project includes a rigging structure, you must send a specific project to rigging@ifema.es before **February 4, 2026.**

IMPORTANT: Projects with rigging included must have both projects approved in order to consider the final approval process completed.

The company in charge of the stand assembly work must pay IFEMA MADRID, before starting such work, the assembly fees corresponding to the services rendered during the period of assembly and disassembly of the Fair. In the event that, as exhibitor, you wish to assume the payment of these assembly fees and have them included in your invoice, you must contract them at the EXPO ZONE. They can be contracted with a 5% discount if the contracting is made up to 30 days before the beginning of the fair assembly. To contract services, you must go through our online channel, which you can access from the following link: [Commerce](#)

In order to be more efficient and provide a better service, avoiding incidents in the assemblies, IFEMA MADRID has begun to apply a last minute surcharge to the hiring of assembly rights, as happens with the rest of our services.

This surcharge increases the price by 25% when the contracting is made during the week prior (7 days before) to the start of the assembly, during the assembly, celebration and disassembly.

DESING YOUR STAND WITH US

In addition to turnkey stands, we offer a comprehensive stand design service tailored to your specific needs, with our full guarantee. We handle everything—from space planning and design to assembly and dismantling. Request a customized project free of charge and without obligation by emailing standbuilding@ifema.es

1. HOW TO PARTICIPATE

ASSEMBLY AND DISMANTLING

Free design booth: the assembly can be carried out from **March 4 to 8, 2026**, with the following schedule:

- From March 4 to March 6 from 6:30 am to 9:30 pm.
- March 7 and 8 from 6:30 am to 7:30 pm.

Modular Stands contracted with IFEMA MADRID: delivery on March 9 from 8:30 am.

Entrance of goods and decoration material:

On March 9 and 10 from 6:30 h to 21:30 h. From 7:00 p.m. on March 10, entry will only be allowed through the pedestrian gates, closing the goods gates to proceed with the installation of recyclable carpeting.

Exhibitors who have not paid in full for the space contracted and the costs of the services requested will not be authorized to occupy the space and will not be handed over the modular stand.

Departure of goods and decoration material: March 13 from 8:30 p.m. to midnight; from 8:30 p.m. to 9:30 p.m. only through pedestrian gates to remove recyclable carpeting, then gates open until midnight.

Dismantling of the stands: March 14 and 15 from 8:30 am to 7:30 pm.

The management of the event may alter the assigned spaces or make changes in the distribution of the pavilions for organizational reasons.

Without prejudice to the EXPODENTAL Management informing exhibitors in the event of relocation or significant alteration of the reserved location, each exhibitor is obliged to inform himself of the location of his stand, its exact dimensions, etc.

Exhibitors who have not paid in full for the space contracted and the costs of the services requested will not be authorized to occupy the space and, if applicable, the modular stand will not be delivered to the exhibitor.

No exhibitor or visitor who cannot be accredited as belonging to the participating professional groups will be allowed access, even if they have the corresponding pass or invitation.

The exhibitor is obliged to attend his stand and remain with the products exhibited during the entire period and opening hours of the event. Failure to comply with these regulations could mean the loss of the right to preferential renewal of the space allocated.

The direct sale of any type of articles exhibited at the fair is strictly forbidden.

The exhibitor authorizes IFEMA MADRID the possible total or partial reproduction of the products exhibited in its promotional material.

The exhibitor undertakes to respect the rules and guidelines for the protection of the environment.



EXPODENTAL

1.7 Specific fair regulations

Activities that may disturb other exhibitors are prohibited and may not exceed 60 decibels.

Promotional activities, distribution and exhibition of samples, brochures, leaflets, flyers and all kinds of promotional material will be carried out only within the space of each exhibitor.

The carrying out of activities that require the contracting of a catering service during EXPODENTAL will require the completion of the form "Communication for catering at stands" available at ifema.es and which should be sent to: catering@ifema.es

It is expressly forbidden for exhibitors to install WIFI access points, either for INTERNET connection or for the presentation of other functionalities. The purpose of this measure is to avoid interference problems, both with the points that may be installed independently by each Exhibitor, as well as the access points of IFEMA MADRID. Such interference could cause the WIFI networks present not to work. For further information, please consult Article 33 of the General Regulations for Exhibitors' Participation in Exhibitions Organized by IFEMA MADRID.

These Specific Regulations are complemented by the General Regulations for Exhibitors' Participation in Exhibitions Organized by IFEMA MADRID, which all exhibitors, by virtue of the fact that they are exhibitors, accept.

Only sanitary products with CE marking obtained according to RD 1591/09 of October 16 may be exhibited at the fair. In those cases in which the products do not have CE marking, it will be necessary to comply with the requirements of Article 41 of this RD, which reads as follows:

Article 41. Exhibitions.

In the fairs, exhibitions and demonstrations they will be able to present products that do not fulfill the dispositions of this royal decree, whenever, in a sufficiently visible poster, placed in the own products or next to them, it is clearly indicated that these products cannot be put in the market nor put in service until their conformity is declared, Such demonstrations will never be able to imply the use of these products in patients.

- Interventions of any kind on people are not allowed, as stated in RD 1591/09. Such demonstrations may never involve the use of such products on patients. Likewise, any type of emission of ionizing radiation or activities involving any type of health risk is forbidden.
- Exhibitors will have to comply with and respect the Code of Ethics of the Healthcare Technology sector available at fenin.es.
- In case of infringement, the Management of the Fair will have the right to close the stand of the infringing company immediately without the right to any type of compensation and may exclude it from future editions of the fair and demand the compensation derived from the expenses incurred by the adoption of this measure.

AUTHORIZATIONS

On the ifema.es website, you will find a list of other services, regulations and forms that may be of interest to you:

- Communication for the realization of catering in stands.
- Occupational risk prevention and coordination of business activities.
- Application for authorization of private security guards at stands.
- Authorization request for wifi installation.
- Authorization request for antenna cabling.
- Request for authorization to hang structures/rigging.

<https://www.ifema.es/en/support/exhibitors-ifema-fairgrounds>

1.8 Participation fees

TYPE OF MODULAR SPACE	FENIN RATES	NO FENIN RATES
FLOOR SPACE ONLY		
From 16,00 to 50,00 sq.m	226€/sq.m + VAT (1)	251€/sq.m + VAT (1)
From 50,50 to 100,00 sq.m	211€/sq.m + VAT (1)	235€/sq.m + VAT (1)
From 100 to 150 sq.m	174€/sq.m + VAT (1)	198€/sq.m + VAT (1)
From 150,50 to 200sq.m	163€/sq.m + VAT (1)	187€/sq.m + VAT (1)
From 200,50 to 250sq.m	152€/sq.m + VAT (1)	178€/sq.m + VAT (1)
From 250,50 to 300 sq.m	141€/sq.m + VAT (1)	173€/sq.m + VAT (1)
More than 300,50 sq.m	135€/sq.m + VAT (1)	167€/sq.m + VAT (1)
Second Floor	108€/sq.m + VAT (1)	127€/sq.m + VAT (1)
MODULARS		
Turnkey stand 16 sq.m	6.105€/sq.m + VAT (1)	6.505€/sq.m + VAT (1)
Turnkey stand 32sq.m	11.353€/sq.m + VAT (1)	12.153€/sq.m + VAT (1)
Additional sq.m Turnkey stand	348€/sq.m + VAT (1)	373€/sq.m + VAT (1)

SERVICES	TARIF
Liability insurance (covers up to 60.000€)	72,84€ + VAT (1)
Multiferia insurance (covers up to 50.000€)	69,15€ + VAT (1)
Minimum power consumption (0,13 kW/sq.m)	7,65€ + VAT (1)
Assembly rights	
Type A: spaces with no decoration, or occupied by carpeting or flooring	2,77€/sq.m + VAT (1)
Type B: basic aluminum modular stands or similar.	5,56€/sq.m + VAT (1)
Type C: modular aluminum design stands, carpentry stands and other materials.	8,85€/sq.m + VAT (1)
CONECTA EXHIBITOR PLAN (former Marketing and Communication Pack + Digital Platform)	395€ + VAT (1)
High co-exhibitor rate	395€ + VAT (1)
Additional exhibitor passes	10,5€/unit. +VAT (1)

(1) Companies based in Spain (excluding the Canary Islands, Ceuta and Melilla): 10% VAT not included. For other companies this operation is not subject to Spanish VAT. For companies based in the European Union, the exhibitor shall be liable to VAT and may, if applicable, claim it back in the country where the company is domiciled.

1.9 Deadlines and payment

Payment of the space reservation fee to participate in the award meetings, according to the following space request brackets:

- From 16 to 150 sq.m.....1.000€.
- From 150,5 to 300 sq.m..... 2.300€
- More than 300,5 sq.m.....4.000€

Discounts:

5% DISCOUNT ON THE TOTAL AMOUNT OF THE CONTRACTED SPACE IF 100% OF THE FLOOR IS PAID BEFORE 5 DECEMBER 2025.

This discount will also be applicable to services contracted by sending the plan of your stand to the technical secretariat. Not included are the mandatory minimum services outdoor advertising, meeting rooms, graphic decoration of stands or specific fair services such as exhibitor passes, invitations....

Surcharges:

25% increase for contracting services, including assembly fees, requested 7 days prior to the start of assembly (25 February 2026).

DATES FOR PAYMENT

- **BEFORE DECEMBER 5:** secure your space with the first 50% of the payment.
- **FEBRUARY 9, 2026:** deadline for payment of 100% of the contracted space and services.

You can pay in the following ways:

- ❖ Transfer to: IFEMA MADRID / EXPODENTAL 2026

Santander: IBAN ES64 0049 2222 5115 1000 1900 SWIFT: BSCHESMM
 BBVA: IBAN ES89 0182 2370 4000 1429 1351 SWIFT: BBVAESMM
 Caixa Bank: IBAN ES93 2100 2220 1102 0020 2452 SWIFT: CAIXESBBXXX

Send a copy of the bank receipt to servifema@ifema.es

- ❖ Certified check made out to IFEMA MADRID/ EXPODENTAL 2026.
- ❖ Credit card in a secure environment, accessible at the end of the online completion of the participation application form, or later through EXPO ZONE. In accordance with current regulations, payments in cash or bearer checks are not accepted.

In **EXPO ZONE** you will find your **statement of accounts** for participation in the fair and the invoices, once the payments have been made. If you need an invoice to make a payment, please request it by mail to servifema@ifema.es

1. HOW TO PARTICIPATE

1.10. Calendar

When	What	How	Who attends you
Until September 15, 2025	Application for participation (priority deadline for choice of space)	Fill in the online application form to participate in the first space allocation and payment of the space reservation fee.	Address of the event: expodental@ifema.es IFEMA MADRID Exhibitors: (+34) 917223000 – atencionalcliente@ifema.es
Until September 16, 2025	Application for participation	Continuation of the process of receiving requests for participation.	Address of the event: expodental@ifema.es IFEMA MADRID Exhibitors: (+34) 917223000 – atencionalcliente@ifema.es
September 23, 24 and 25, 2025	1st Allocation of Spaces	All companies that have sent their Participation Application Form and have paid the space reservation fee.	Address of the event: expodental@ifema.es IFEMA MADRID Exhibitors: (+34) 917223000 – atencionalcliente@ifema.es
To December 5, 2025	Payments	<ul style="list-style-type: none"> - Payment of 50% of the amount of the space upon receipt of the space allocation. - 5% discount if 100% of the amount of the contracted floor is paid.. 	Servifema: servifema@ifema.es IFEMA MADRID Exhibitors: (+34) 917223000 – atencionalcliente@ifema.es
From february 4, 2026	Customization of modular stands	Modifications to the partial plan of the stand (location of walls, coat racks, shelves, furniture, etc.) must also be made through Zona Expo prior to the start of assembly.	Technical Secretariat IFEMA MADRID Exhibitors: (+34) 917223000 – atencionalcliente@ifema.es
Until February 5, 2026	Contracting of services	Services contracting with a 5% discount.	Technical Secretariat Technical Secretariat
Until February 9, 2026	Speaker´s Corners	<ul style="list-style-type: none"> - To reserve an activity in Speaker's Corners ASSOCIATED with FENIN - Deadline to pay the last payment of the 100% of the contracted space 	expodental@ifema.es
Until February 11, 2026	Free design projects	Deadline for uploading free design projects to the EXPO ZONE. If the project includes hanging elements, you must submit a separate project and send it to rigging@ifema.es	IFEMA MADRID Exhibitors: (+34) 917223000 – atencionalcliente@ifema.es
Until February 16, 2026	Speaker´s Corners	To book an activity at Speaker's Corners not FENIN associated.	expodental@ifema.es

1. HOW TO PARTICIPATE

1.10. Calendar

When	What	How	Who attends you
Until February 17, 2026	Carpet color	Choice of carpet color through ZONA EXPO.	Technical Secretariat IFEMA MADRID Exhibitors: (+34) 917223000 – atencionalcliente@ifema.es
Until February 24, 2026	Stand signage	Complete the stand signage through ZONA EXPO.	Technical Secretariat IFEMA MADRID Exhibitors: (+34) 917223000 – atencionalcliente@ifema.es
Until February 25, 2026	Contracting of services	25% increase on prices for last minute contracting of assembly rights and all other services.	IFEMA MADRID Exhibitors: (+34) 917223000 – atencionalcliente@ifema.es
March 4 to 8, 2026	Stand assembly	- From March 4 to 6 from 6:30 a.m. to 9:30 p.m. - March 7 and 8 from 6:30 a.m. to 7:30 p.m.	-
March 9 and 10, 2026	Customization of modular stands	Starting at 8:30 a.m.	Hall manager
	Goods receipt	From 6:30 a.m. to 9:30 p.m. From 7:00 p.m. onwards, entry will only be possible through the pedestrian doors, closing the goods gates to proceed with the installation of recyclable carpeting in aisles.	
March 11 to 13, 2026	Celebration of the fair	Schedule from 10:00 a.m. to 8:00 p.m.	-
March 13, 2026	Goods issue	From 8:30 p.m. to 12:00 p.m., exit will only be possible through the pedestrian gates for the removal of recyclable carpeting. After that time the merchandise gates will be opened until 12:00 p.m.	Hall manager
March 14 and 15, 2026	Dismantling of stands	Hours from 8:30 a.m. to 7:30 p.m.	Hall manager

2.1. EXPO ZONE. Manage your participation and your space. Contracting additional services. E-commerce

Access our customer area ZONA EXPO from the web: <https://www.ifema.es/en/expodental> to manage your company data, your contacts and everything related to your participation. You will be able to access your participation once you have confirmed your participation with your user (the e-mail address you used to fill in the application form).

What can I do from EXPO ZONE?

- Access details of each participation, floor plans, and projects.
- Access the exhibitor's calendar.
- View documents of interest.
- Manage exhibitor passes and request visa support letters.
- Download discount vouchers: Renfe and Iberia.
- Send invitations.
- Register co-exhibitors.
- Access orders, payments, account statements and invoices issued.
- Upload free design stand projects.
- Request the distribution of modular stand elements, such as coat racks or shelves, add the sign, and choose the carpet color.
- Access e-commerce for contracting services.

2.2. Registration of CO-EXHIBITORS

The registration of co-exhibitors must be done by the exhibitor from the EXPO ZONE, section "Manage your participation/Attach co-exhibitors".

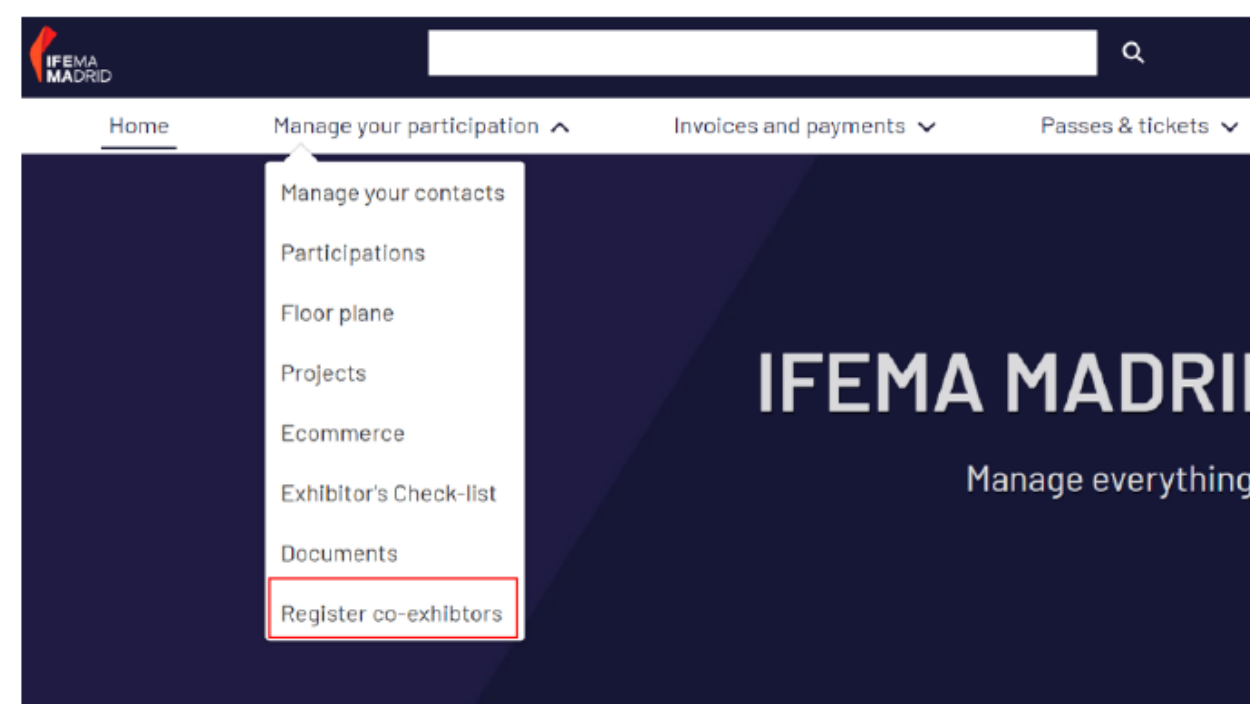

To register, it is essential to enter a correct and unique e-mail address for each co-exhibitor and indicate whether the participation fee (CONNECTA EXHIBITOR PLAN) will be paid by the exhibitor or by the co-exhibitor.

The condition of co-exhibitor implies the obligatory contracting of the elements included in the CONECTA EXHIBITOR PLAN (Marketing and Communication Pack + Digital Platform):

Registration fee per co-exhibitor 395€ + VAT (1)

Once this process has been completed, the co-exhibitor will receive a unique code to be included in his/her participation application*.

***If the exhibitor assumes the cost of participation of the co-exhibitor, his registration will be confirmed with the sending of the participation application (essential requirement).**

***If the co-exhibiting company assumes the cost of its participation, its registration will be confirmed with the sending of the participation application and the payment of the corresponding amount.**

Each registered co-exhibitor will have at its disposal the elements included in the CONECTA CO-EXHIBITOR PLAN:

- Access to EXPODENTAL Digital Platform.
- Presence in the online exhibitor catalog. Visibility in the official list of exhibitors accessible at [ifema.es/expodental](https://www.ifema.es/expodental).
- Access to your own EXPO ZONE.
- 2 Exhibitor Passes.
- Online invitations.

(1) Empresas establecidas en el territorio español (excluyendo Canarias, Ceuta y Melilla): 10% de IVA no incluido. Para el resto de empresas esta operación queda no sujeta a IVA español. En caso de empresas de la Unión Europea, el expositor será responsable del IVA que, en su caso, se devengue en su país de establecimiento.

2. MANAGE YOUR PARTICIPATION

2.3. Exhibitor/co-exhibitor passes, transport discount vouchers, visas and invitations

EXHIBITOR PASSES

Exhibitor passes will be managed from EXPO ZONE, in the section "Access to the event/Exhibitor passes".

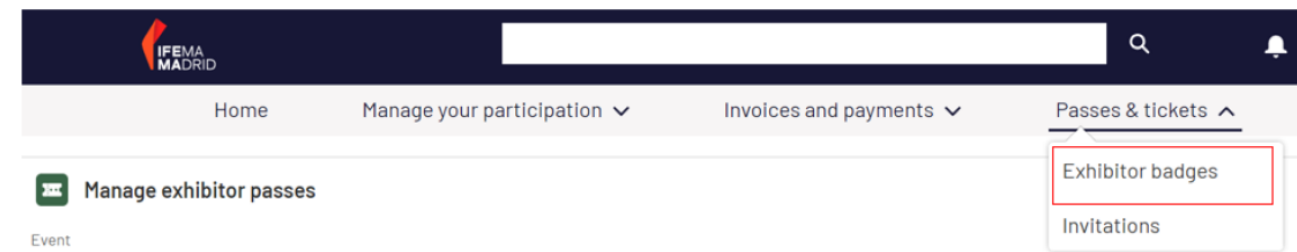

Each exhibitor will be assigned the passes that correspond to the contracted area:

- For every 5 sq.m contracted1 exhibitor pass

In order to ensure professionalism at the fair, all exhibitor badges will be personalized: they will include the name of the badge holder, company and country. In order to avoid misuse, identity checks may be carried out at the entrances to EXPODENTAL.

Exhibitors may purchase additional exhibitor passes (**€10,5/each +VAT**) through EXPO ZONE.

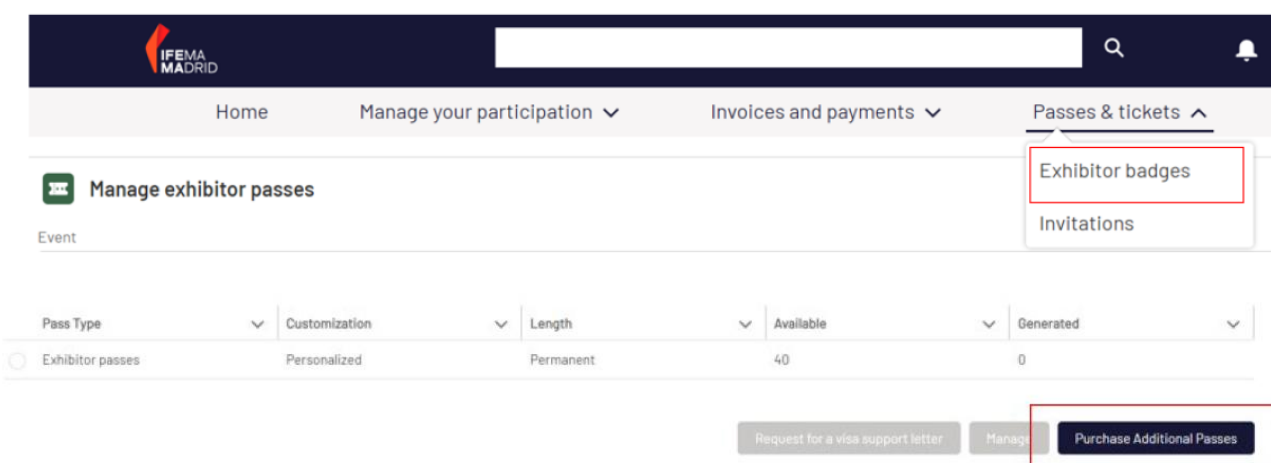

CO-EXHIBITOR PASSES

The co-exhibitor must manage their **exhibitor passes** in the **EXPO ZONE**:

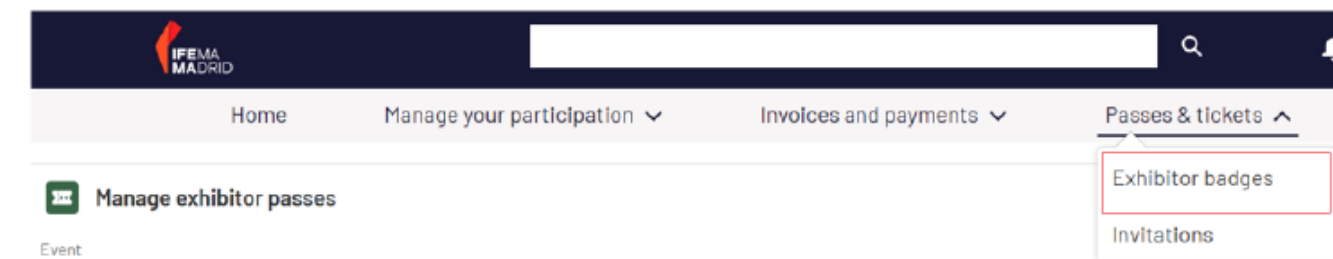

2. MANAGE YOUR PARTICIPATION

ON-LINE INVITATIONS

Each exhibiting company will have available in the EXPO ZONE, an INVITATION CODE with a number of uses according to the contracted surface (**5 for each sq.m**) that can be sent to their clients to register for free in Expodental.

The professionals who receive the invitation code must register ONLINE through the EXPODENTAL website, ifema.es/expodental, in the section "Purchase your pass" and enter the invitation code received to obtain their free pass to access the fair. (Invitation codes cannot be redeemed at the counter).

The visitor's pass is valid for the 3 days of the fair.

Invitations will be sent through "EXPO ZONE/Access to the event/Invitations/Manage invitations".

Following screen will appear for you to customise the sending:

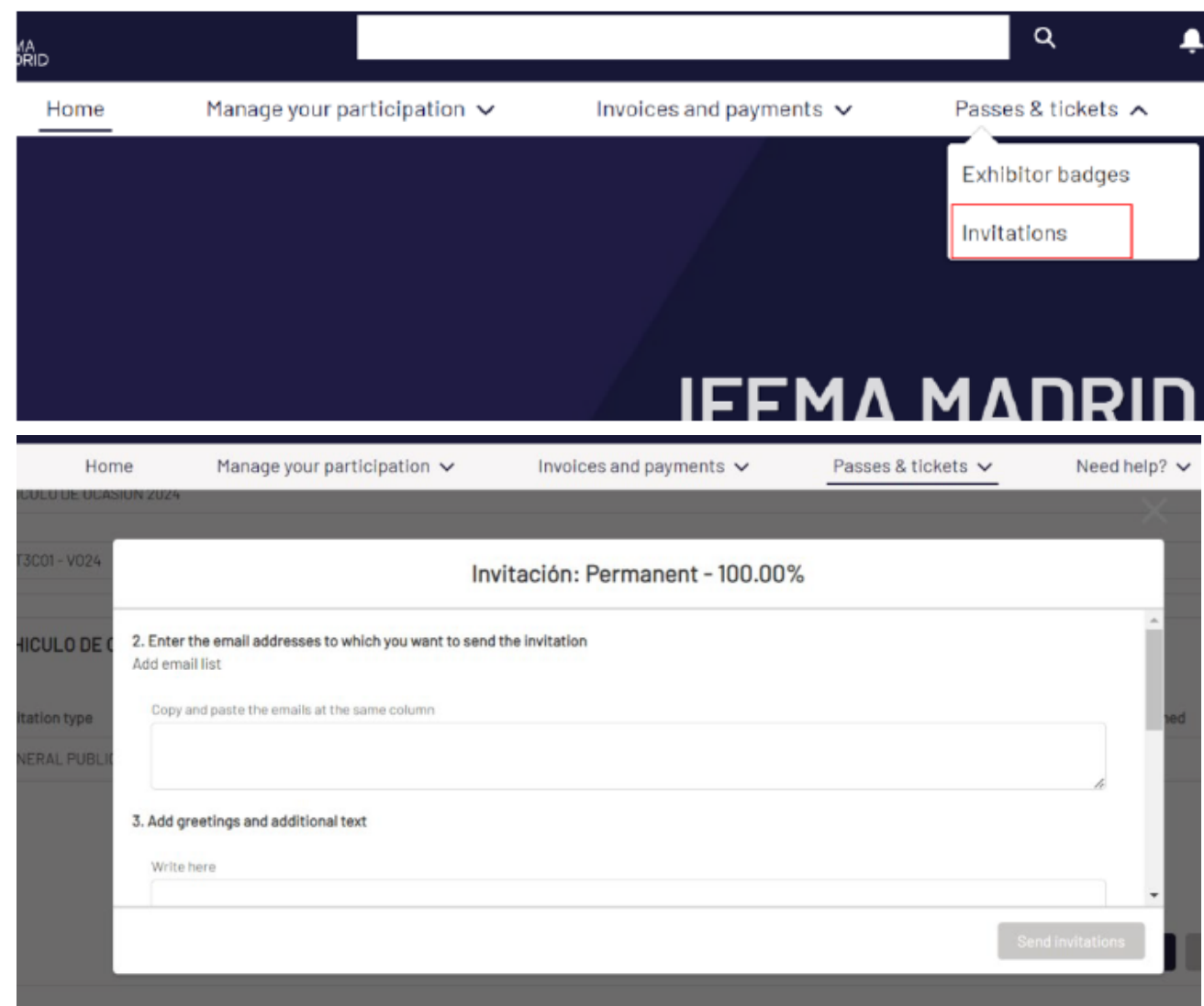

We appeal to exhibitors to make good use of the invitations, sending them exclusively to professionals of the sector in order to guarantee the professionalism of the fair. Access controls may be carried out for this purpose.

It will be absolutely necessary for all Professional Visitors who are going to access the exhibition site with a Professional Invitation, to be accredited as Professionals, through ifema.es/expodental

VISA MANAGEMENT

If you require a visa to travel, **you can request from ZONA EXPO, the letters of support to manage it.** To do so, you must **first customize** the exhibitor pass and have formalized the payment of your **participation following** the payment schedule (see point 1.8).

Once these two requirements are fulfilled, from "EXPO ZONE/Event Access/Exhibitor Passes" you will have access to the "Request visa support letter" button.

We advise you to start the process as soon as possible since the deadline for visa application is usually at least 30 days before traveling.

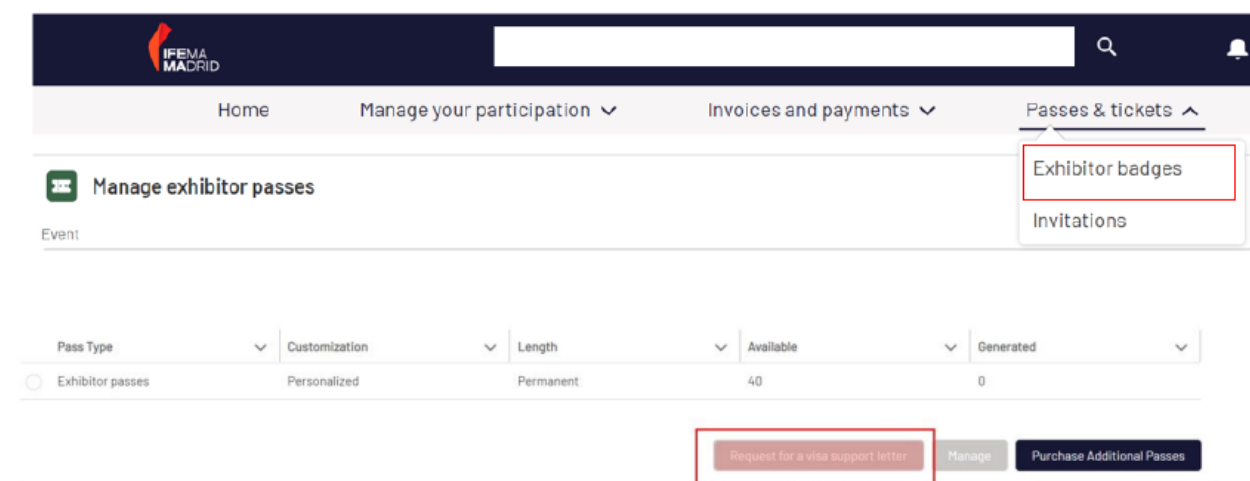

TRANSPORT DISCOUNT VOUCHERS

Once the exhibitor passes have been requested, the **corresponding discount vouchers for transportation can be downloaded from EXPO ZONE**, in the section "Manage your participation/Documents".

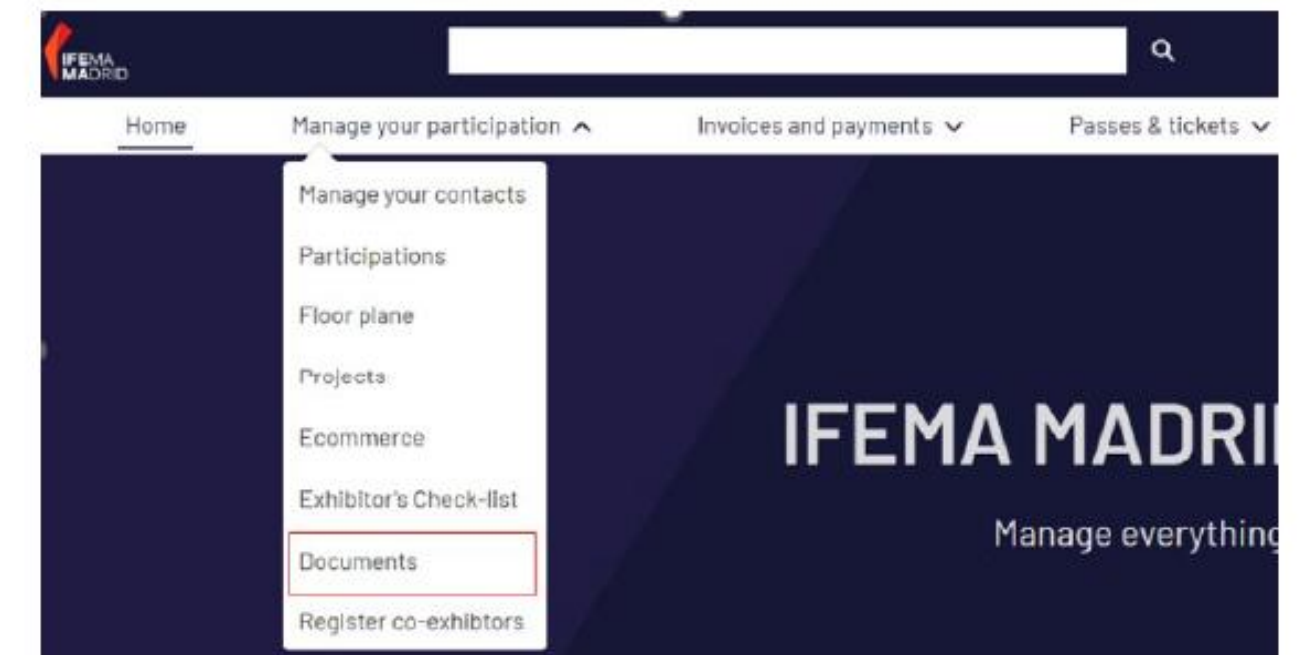

2.4 Other relevant information

Shipment of merchandise to the premises. Customs regulations.

IFEMA MADRID staff is not authorized to receive any goods destined for your stand. In order to send goods to the venue, the exhibitor must indicate in the delivery address:

- ♦ IFEMA MADRID (Avda. del Partenón, 5. 28042 Madrid. Spain)
- ♦ EXPODENTAL Fair
- ♦ Name of your company.
- ♦ Hall and stand number.

The goods must be received by your company's personnel at your stand and must arrive during the days destined for the entry of goods and decoration.

In case it is not possible to comply with the above, we recommend you to contact our partner company for goods management (handling and warehousing):

DB Schenker office at IFEMA Trade Fair Center MADRID: Hall 7
Phone: +34 91 330 51 77
ifema.madrid@dbschenker.com

CUSTOM REGULATION

1. All products coming from non-EU countries must go through customs procedures, with special mention to the fact that, since 1 January 2020, the United Kingdom has been treated as a third country, so all shipments originating from the United Kingdom must regularise their merchandise through the corresponding customs procedure.
2. Exhibiting companies must have the details of the customs agent clearing their goods or, failing this, a copy of the customs documentation for entry into the European Union.
3. The material or merchandise for distribution or consumption is subject to Spanish taxes, even if they are products with no commercial value (depending on the country, the amount of taxes may vary).
4. All goods subject to a temporary regime must not be moved from the stand or leave the IFEMA MADRID trade fair centre until their situation has changed and customs formalities have been completed. It may only be deposited during these formalities in the warehouse of the official logistics agent within the trade fair centre.
5. It is strictly forbidden to sell or distribute non-Community goods at a trade fair before customs clearance has been completed.

6. Products transported as hand luggage must be declared at Barajas Airport in the RED CHANNEL ("Something to declare") and the goods must be cleared with the corresponding authority at the airport.
7. Goods that have not passed customs control and are on display will be confiscated by the customs authorities operating at the Trade Fair Centre until the appropriate documents are presented.
8. Any lorry arriving at IFEMA MADRID under a transit consigned to IFEMA MADRID, must go to the warehouse of the official Logistics Operator, for the regularisation of the transported goods, located at:

Avenida Partenón s/n
Entrada Oeste - Access on calle Rivera del Sena
Pabellón de servicios nave 2
28042 Madrid, Spain

In order to avoid undesired incidents, and for any questions you may have, please contact our Customs Operator, DB SCHENKER: (+34) 91 330 51 77: email: ifema.madrid@dbschenker.com

2. MANAGE YOUR PARTICIPATION

EXPODENTAL

2.5. Map

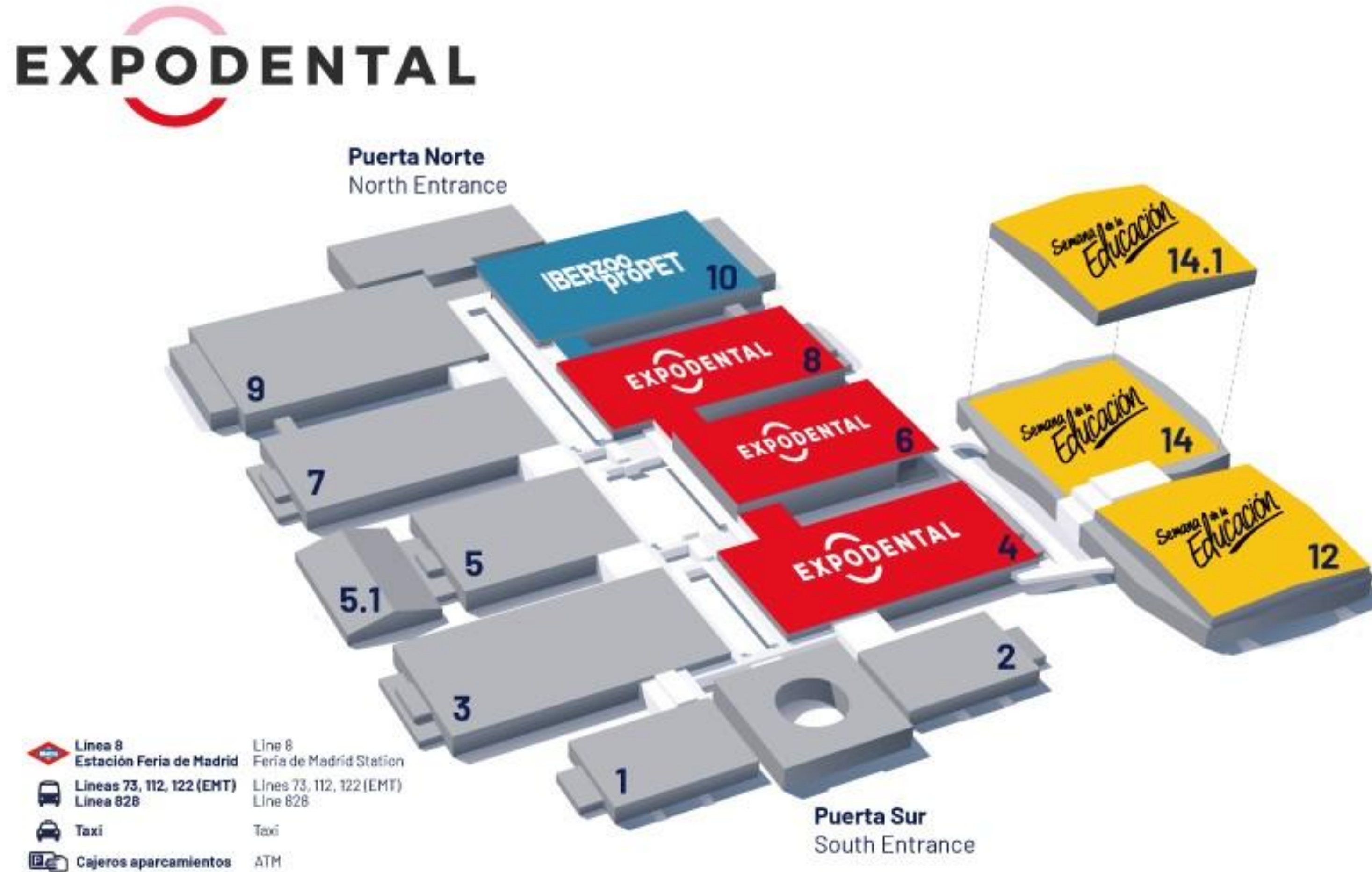

2.6. FAQ's

Question	Answer
<p>Where can I consult the IFEMA MADRID General Rules of Participation to which my participation is subject?</p>	<p>In addition to the Exhibitor's Guide, your participation in EXPODENTAL is subject to the IFEMA MADRID General Rules of Participation, which you should be informed about and which you can access from the IFEMA MADRID website (www.ifema.es) as well as from the following link IFEMA MADRID General Rules of Participation.</p>
<p>Can I hire a catering service or serve my own food and beverages at the stand?</p>	<p>Yes, exhibitors who are going to offer, free of charge, a catering service on their stand may do so either by submitting their request to the catering companies approved by IFEMA MADRID (Consult the list HERE) or through other catering service providers, in which case it is essential to complete the form 'Communication for the provision of catering services on stands' available in the exhibitors' area of the institutional website and send it, with the information requested therein, to catering@ifema.es for its knowledge and appropriate effects. If IFEMA MADRID is not notified of the above, the Exhibitor will not be able to offer this service at its stand. The Exhibitor assumes liability to third parties for claims arising from the aforementioned catering service, exonerating IFEMA MADRID from any liability in this respect.</p> <p>Catering Parking/Refrigerated Trucks: There is a parking area for catering vehicles and refrigerated trucks, with the possibility of electrical connection. You can hire it through the eCommerce</p>
<p>Can I access the trade fair centre with vehicles for assembly and disassembly or loading and unloading of goods?</p>	<p>Access to IFEMA MADRID and to the interior of the halls will be through the doors and on the days and times indicated in this Exhibitor's Guide. Access to the inside of the halls will be exclusively for unloading materials. Vehicles may not remain parked inside the halls or in adjacent areas.</p> <p>We remind you that, for occupational safety reasons, it is strictly forbidden to park in front of the goods entrance gates. IFEMA MADRID is not responsible for the surveillance of vehicles while at Feria de Madrid.</p> <p>There is a parking area for trucks and another for cars, which may be used by paying, if applicable, the corresponding fees. Consult rates</p>
<p>Can I have a vehicle on my stand?</p>	<p>Vehicles with combustion engines used for exhibition purposes must have a fuel tank filled with the minimum fuel required to access and leave the allocated space at the end of the exhibition.</p>

2.6. FAQ's

Question	Answer
Can I send goods to my booth?	<p>IFEMA MADRID staff are not authorised to receive merchandise for your stand. In order to send merchandise to the venue, the exhibitor must indicate the delivery address: IFEMA MADRID (Avda. del Hall , 5. 28042 Madrid. Spain). EXPODENTAL Trade Fair Name of your company. Hall and stand number.</p> <p>The merchandise must be received by your company's staff at your stand and arrive on the days set aside for incoming merchandise and decoration. If it is not possible to comply with the above, we recommend that you contact your freight forwarding partner: DB Schenker office at the IFEMA Trade Fair Centre MADRID: Hall 7, (+91) 330 51 77 ifema.madrid@dbschenker.com</p>
What procedure do I have to follow to hang structures in the halls/rigging?	<p>Exhibiting companies may hang elements from the ceiling of the halls following the procedure shown in the "Regulations for hanging structures in Halls" and by completing the form "Application for authorisation for hanging structures/rigging" and sending it to: rigging@ifema.es</p>
How do I apply for a visa support letter?	<p>Visa support letters are managed through the EXPO ZONE. To do so, you first have to personalise your exhibitor passes. Once you have managed your exhibitor passes, you can request your support letters and download them to your computer.</p> <p>It is essential to be up to date with payments according to the payment schedule in order to be able to apply for the letters.</p>
Where can I book the services for my stand?	<p>Either through the e-commerce section inside the EXPO ZONE or via the link: https://shop.ifema.es</p>
Who do I contact to book a room?	<p>Exhibitors who need to book a room should contact with: uanproduccion@ifema.es</p>

2.6. FAQ's

Question	Answer
What is included in the CONECTA EXHIBITOR PLAN (former Marketing and Communication Pack + Expodental Digital Platform)?	<p>This must-hire concept includes the following elements :</p> <ul style="list-style-type: none">• Expodental Digital Platform.• Presence in the exhibitors' catalog available on the official website of the event.• Presence on the floor plans located in each of the pavilions. <p>And the following services:</p> <ul style="list-style-type: none">• Access to the EXPO ZONE.• Exhibitor passes according to the contracted area.• Invitations and delivery service through the EXPO ZONE.• Wifi connection for 3 users throughout the fair for booth holders (Devices that allow connection in the 5 GHz band).• Access keys will be sent the days prior to the start of the fair.
How to use the EXPO ZONE?	<p>The following video shows a tutorial on the use of the EXPO ZONE</p>
What are the features of my EXPO ZONE?	<p>It is used to manage the participation of each exhibiting company in Expodental:</p> <ul style="list-style-type: none">• Registration of the contacts that will access the Expo Zone and management of access permissions.• Access to the exhibitor's calendar.• View documents of interest.• Manage exhibitor passes, request visa support letters and send invitations.• Register co-exhibitors.• Access to payments, account status and invoices issued.• Upload free design booth projects and distribution of modular booth elements.• Add signage and choose carpet color for exhibitors with modular booths.• Access to e-commerce for the contracting of services.

2.6. FAQ's

Question	Answer
<p>What are the features of my Digital Platform ?</p>	<ul style="list-style-type: none"> • It is used to manage the participation of the company in the Digital Platform catalog and the Expodental • Show product and service offerings. • Schedule appointments for professional meetings. • Sign up other team members with access to Digital Platform. • Complete your professional profile on the platform and my agenda of availability for meetings. • Search for contacts of interest in the professional network. • Consult activities with the possibility of scheduling them. • View information on the offer of other exhibitors. • Scan professional visitor badges at the fair. • Request and accept to be contacted for chatting and videoconferences.
<p>How can I request my invoices?</p>	<p>Invoices are not generated by default. You must request them directly from the IFEMA MADRID invoicing department (servifema@ifema.es) indicating the event at which you are exhibiting and the items to be included in the invoice. Once it has been generated, it will be available in your EXPO ZONE.</p>
<p>What is the difference between floor only and turnkey stand basic?</p>	<ul style="list-style-type: none"> • Floor Space Only : it is the exhibitor who has to make a free design stand and submit it for approval by the Expodental Technical Secretariat or hire it through the stand design service offered by IFEMA MADRID, build a stand with us. This modality includes only the contracting of the space and the compulsory elements (insurance, minimum electricity consumption). • Modular stand: delivered assembled. The structure of the stand is made of aluminum and the panels are made of melamine. See description in section 1.6 <p>The Conecta Exhibitor Plan must be contracted, regardless of the type of assembly (floor only or modular).</p>
<p>Can I decorate and/or set up my stand with IFEMA?</p>	<p>IFEMA MADRID offers two main services:</p> <ul style="list-style-type: none"> • Graphic decoration for stands: Customize your modular stand with the image of your brand generating maximum impact on visitors. There is a wide range of versatile graphic materials adaptable to walls, furniture, fronts, banners, etc. You can request information and a quote at decoraciongrafica@ifema.es • Stand design: consists of an integral service of stand design totally adapted to your needs. From the planning of your space, design, assembly and disassembly. You can request information and budget at standbuilding@ifema.es

2.6. FAQ's

Question	Answer
Is it compulsory to attend the booth at all times?	Yes, exhibitors must not leave their stand unattended and must remain with the products on display throughout the entire period and opening hours of the event.
Are assembler's passes necessary during the set-up of the trade fair?	No. The requirements to be allowed to enter and set up are to have paid 100% of your participation, to have the project presented and approved, to have paid the assembly fees, and to have completed the occupational risk protocol.
How can I book parking at IFEMA?	Exhibiting companies will be able to book parking spaces through the e-commerce section inside the EXPO ZONE or via the link https://shop.ifema.es . Once the contract has been signed, parking badges can be collected from March 4 (first day of stand set-up) at the exhibitor services desk, located in the central boulevard between halls 4, 6 and 8.
What coverage do I have as an exhibitor with the insurance included?	You can check the coverage of the compulsory insurance policies at the IFEMA MADRID exhibitor support area .
How can I access the WI-FI network as an exhibitor?	As an exhibitor you will receive as part of the CONNECT PLAN a Wi-Fi connection for 3 users during the entire trade fair for the exclusive use of stand holders. Devices that allow 5GHz network capability are required. Access codes will be sent out during the lead up to the event. Additional Wi-Fi access can be booked through the e-commerce section inside the EXPO ZONE or via the link https://shop.ifema.es
Regulations and support for exhibitors at the trade fair centre	https://www.ifema.es/en/support/exhibitors-ifema-fairgrounds/
Regulations and support for fitters at the trade fair centre	https://www.ifema.es/en/support/assemblers-colaborators-fairgrounds

3. PROMOTE AND MAXIMIZE YOUR PARTICIPATION

EXPODENTAL

3.1 Exhibitor catalogue

The fair's catalogue, or list of exhibiting and co-exhibiting companies, is an essential tool for promotion and networking. It provides visitors and other exhibitors with the basic information needed to prepare for the fair and helps them find and contact you before, during, and after the event.

- Enter and update your contact details, the products or services presented, and any relevant information to give your company maximum visibility and ensure you get the most return from your participation.
- All the digital environment and communication for your participation is channeled through Digital Platform.
- Make the most of the platform offered by IFEMA MADRID to promote your participation, schedule appointments, showcase your products, and connect with your target audience.

3.2. Speaker's Corners:

EXPODENTAL provides all exhibitors with a space dedicated to presentations, lectures or demonstrations aimed at disseminating knowledge, professional networking and brand visibility within the event.

The form will be sent to you by email.

3.3. Networking

Enhance your contact list

Digital Platform gives you the opportunity to search for contacts among its participants. You can use filters such as country, activity, job title, products of interest, etc., to perform searches. Once you've identified potential clients, you can chat with them, request contact details (such as email and phone number), or invite them to a meeting at the fair.

Be proactive and take advantage of this opportunity to build a valuable contact list.

Meeting requests can be directed to the company in general or to a specific team member. This way, the entire team can plan their meeting schedule at the fair in advance.

3.4 Outdoor advertising

Advertising projects tailored to your needs:

- Promote your brand before, during and after the event.
- Attract new customers through the best B2B segmentations in the market.

More information here: IFEMA MADRID Advertising:

You can explore these options on the fair's website in the exhibitor area under "advertising services and promotional elements," or by sending an email to publicidad@ifema.es or by calling (+34) 91 722 53 08 / 40.

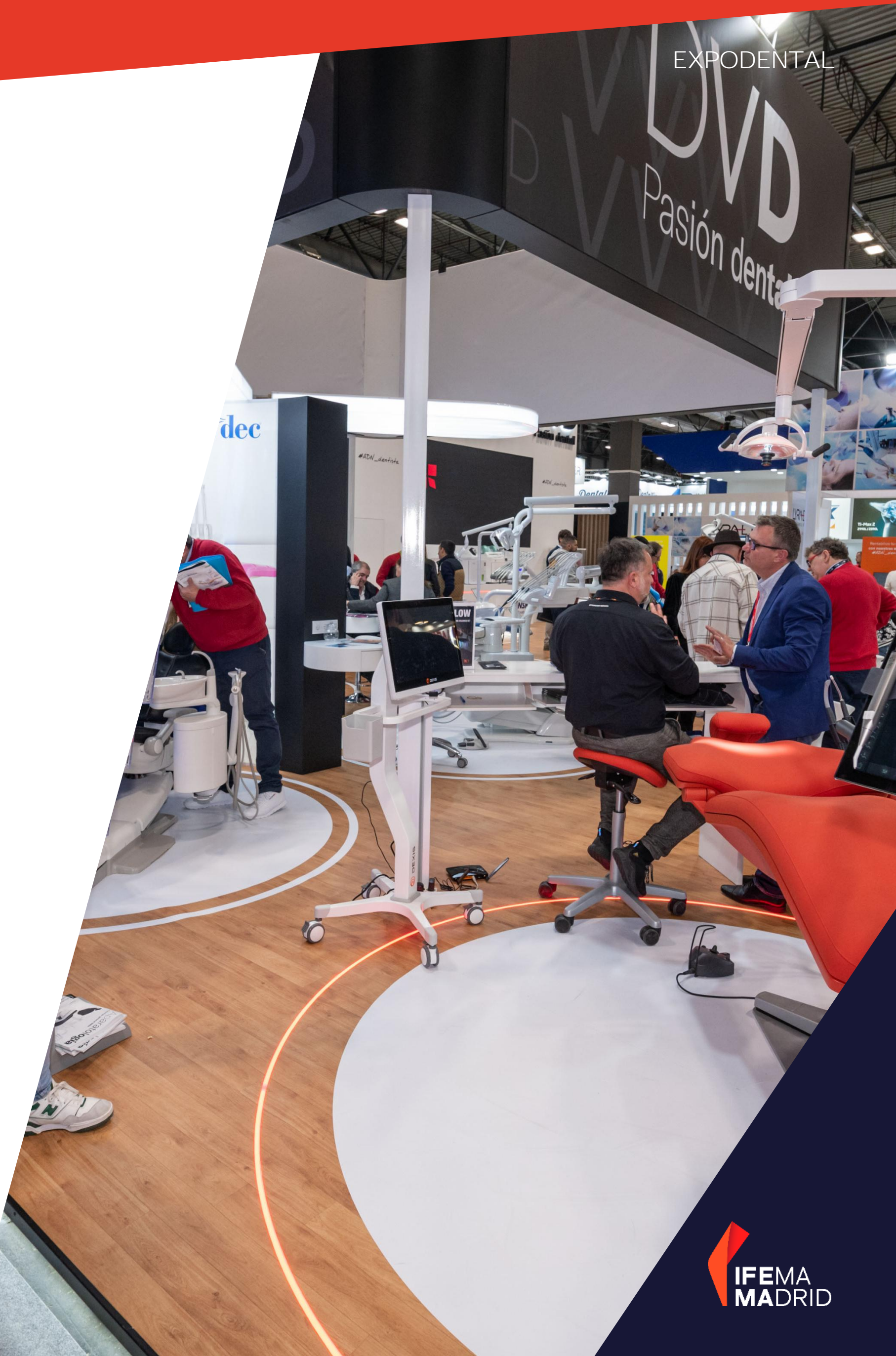

4. Sustainability Culture Management at IFEMA MADRID

EXPODENTAL

At IFEMA MADRID we are not only fully committed to sustainability per se, but also to achieving the sustainable development goals (hereinafter SDGs) promoted by the United Nations, which we have incorporated into our strategic corporate management policy and culture

IFEMA MADRID sustainability policy is mainly focused on the following SDGs: 8, 9, 11, 12, 13, 16 and 17.

IFEMA MADRID'S sustainability policy is mainly based on the following SDGs: Nos. 8, 9, 11, 12, 13, 16 and 17.

ISO Standards certified by IFEMA MADRID:

- ISO 9001: Quality Management,
- ISO 20121: Event Sustainability Management.
- ISO 14001: Environmental Management,
- ISO 50001: Energy Management,
- ISO 22320: Emergencies Management.

ACTIONS TAKEN AT IFEMA MADRID TO REDUCE GAS EMISSIONS AND BE MORE ENERGY EFFICIENT:

- 100% certified electrical energy of renewable origin.
- Geothermal installation in Puerta Sur building.
- Low consumption lighting in our halls and on our modular stands.
- Controlling the temperature of our air-conditioning / HVAC systems.

IFEMA MADRID is in possession of calculate and I reduce stamps in Carbon Footprint Scopes 1 and 2.

WASTE MANAGEMENT:

• The exhibitor/assembler is the generator of the waste and shall therefore be responsible for its removal and management. How the waste generated by the exhibitor is managed is explained in article 35 of the General Rules of Participation.

• We offer our exhibitors a service that includes the removal and management of the waste they/their assemblers generate. (check our fees in Exhibitors' Area).

Carpet recycling:

IFEMA MADRID recycles 100% of the carpeting used in aisles and communal areas. To do so it has been essential to change our assembly and disassembly process, that affects the entry and removal of goods (check the corresponding item) . Furthermore, means that it has to be laid in strips instead of covering the entire surface area as was previously the case. This means we can guarantee its conversion into a new raw material for the subsequent manufacture of other products.

SUSTAINABLE MOBILITY:

IFEMA MADRID offers access to public transport close to its facilities (metro and bus), parking for electric cars with 100% renewable electricity charge points, as well as a parking area for bicycles and scooters

GUIDE TO SUSTAINABLE PARTICIPATION IN TRADE FAIRS/EVENTS:

IFEMA MADRID has published its Guide to Sustainable Participation in Trade Fairs for exhibitors on its website. We recommend you read it before starting to prepare your participation:

ifema.es/en/about-us/quality-sustainability



Department	Ask me about	Contact		
Commercial Department	<ul style="list-style-type: none"> Contracting space General topics of participation in the fair Exhibitor passes Trade visitor invitations Activities and forums at the Fair. 	Director	Félix Pérez-Fajardo	(+34) 91 722 30 00 expodental@ifema.es
		Commercial Manager	Valentina Brambilla	
		Commercial Area	Encarna López	
IFEMA MADRID Customer Service	<ul style="list-style-type: none"> Hiring of services Expo Zone Visitor information 	(+34) 91 722 30 00 atencionalcliente@ifema.es		
Technical Secretariat (Trade Fair Services Department)	<ul style="list-style-type: none"> Technical support to exhibitors and assemblers Review of stand assembly projects Solutions to technical problems during the exhibition activity Customization of modular stands 	(+34) 91 722 30 00 stecnica@ifema.es		
Graphic decoration	Hiring of graphic materials to customize your booth	(+34) 91 722 30 00 decoraciongrafica@ifema.es		
Graphic decoration	Design and assembly of free design stands	(+34) 91 722 30 00 standbuilding@ifema.es		

5. CONTACT US

Department	Ask me about	Contact	
Outdoor Advertising	Hiring of advertising media at the fairgrounds	(+34) 91 722 53 40/08 publicidadexterior@ifema.es	
Communication and Marketing Management	Media relations	Director: Raúl Díez International press: Elena Valera Press secretariat: Pablo Santos	Tlf.: (34) 627 70 60 89 Email: psantos@ifema.es
Planning and Control Management	<ul style="list-style-type: none"> Rental of the different meeting and convention spaces at the fairgrounds, both during and outside the fairs. Coordination of extra-fair activities 	(+34) 91 722 30 00 uanproduccion@ifema.es	
Institutional Relations (Protocol)	<ul style="list-style-type: none"> Institutional visits Guided tours Protocol for all Events Institutional relations 	(+34) 91 722 30 00 relacionesinstitucionales@ifema.es	
Safety and Self-Protection Management	<ul style="list-style-type: none"> General security and parking Access to the Fairgrounds Coordination for stand catering 	(+34) 91 722 50 65 dseguridad@ifema.es catering@ifema.es	
Medical Service and Security Emergencies	<ul style="list-style-type: none"> Medical emergency Health care for exhibitors and visitors during the celebration of fairs, set-up and dismantling. 	(+34) 91 722 54 00	

Thank you

